

benzlers

with you at every turn

Series F3 - Shaft Mounted Geared Motor
Installation & Maintenance

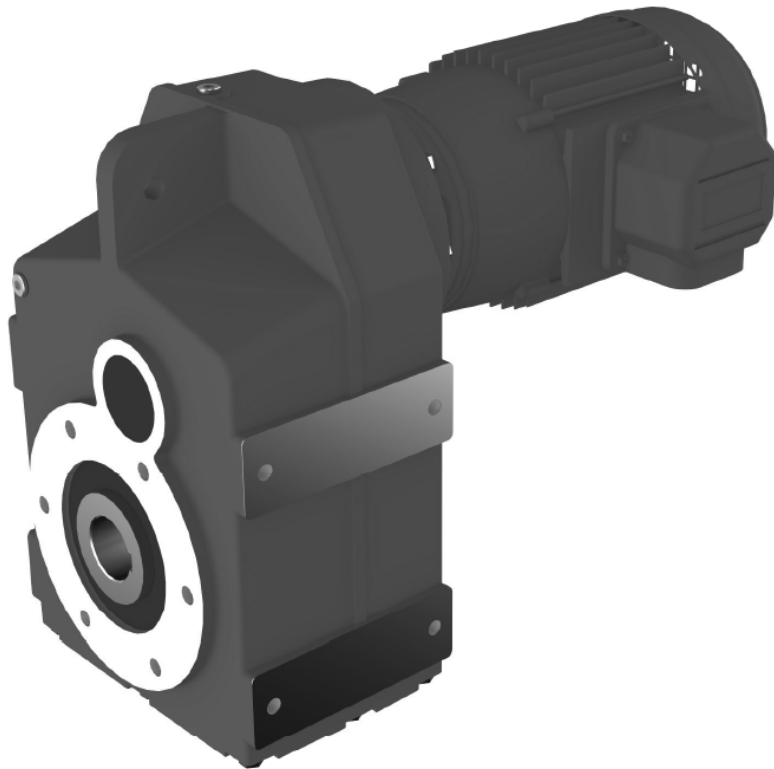

radicon

with you at every turn

IF-3.02GBA0924

IMPORTANT

Product Safety Information

General - The following information is important in ensuring safety. It must be brought to the attention of personnel involved in the selection of AB Benzlers equipment, those responsible for the design of the machinery in which it is to be incorporated and those involved in its installation, use and maintenance.

AB Benzlers is not liable for damage arising from non-compliance of the operating manual.

The operating manual is a part of the product.

- Always keep the operating manual ready to hand near the product as it contains important information.
- Pass on the operating manual if the product is supplied with main equipment / machine.

AB Benzlers equipment will operate safely provided it is selected, installed, used and maintained properly. As with any power transmission equipment **proper precautions must be taken** as indicated in the following paragraphs, to ensure safety.

Potential Hazards - these are **not** necessarily listed in any order of severity as the degree of danger varies in individual circumstances.

Instructions on the protective measures to be taken by the user, including where appropriate, the personal protective equipment to be provided.

It is important therefore that the list is studied in its entirety:-

1) **Fire/Explosion**

- a) Oil mists and vapour are generated within gear units. It is therefore dangerous to use naked lights in the proximity of gearbox openings, due to the risk of fire or explosion.
- b) In the event of fire or serious overheating (over 300°C), certain materials (rubber, plastics, etc.) may decompose and produce fumes. Care should be taken to avoid exposure to the fumes, and the remains of burned or overheated plastic/rubber materials should be handled with rubber gloves.

2) **Guards** - Rotating shafts and couplings must be guarded to eliminate the possibility of physical contact or entanglement of clothing. It should be of rigid construction and firmly secured.

3) **Noise** - High speed gearboxes and gearbox driven machinery may produce noise levels which are damaging to the hearing with prolonged exposure. Ear defenders should be provided for personnel in these circumstances.

4) **Lifting** - Where provided (on larger units) only the lifting points or eyebolts must be used for lifting operations (see maintenance manual or general arrangement drawing for lifting point positions). Failure to use the lifting points provided may result in personal injury and/or damage to the product or surrounding equipment. Keep clear of raised equipment.

5) **Lubricants and Lubrication**

- a) Prolonged contact with lubricants can be detrimental to the skin. The manufacturer's instruction must be followed when handling lubricants.
- b) The lubrication status of the equipment must be checked before commissioning. Read and carry out all instructions on the lubricant plate and in the installation and maintenance literature. Take notice of all warning tags. Failure to do so could result in mechanical damage and in extreme cases risk of injury to personnel.

6) **Electrical Equipment** - Observe hazard warnings on electrical equipment and isolate power before working on the gearbox or associated equipment, in order to prevent the machinery being started.

7) Installation, Maintenance and Storage

- a) In the event that equipment is to be held in storage, for a period exceeding 6 months, prior to installation or commissioning, AB Benzlers must be consulted regarding special preservation requirements. Unless otherwise agreed, equipment must be stored in a building protected from extremes of temperature and humidity to prevent deterioration.
- b) The rotating components (gears and shafts) must be turned a few revolutions once a month (to prevent bearings brinelling). External gearbox components may be supplied with reservative materials applied, in the form of a "waxed" tape overwrap or wax film preservative. Gloves should be worn when removing these materials. The former can be removed manually, the latter using white spirit as a solvent.
Preservatives applied to the internal parts of the gear units do not require removal prior to operation.
- c) Installation must be performed in accordance with the manufacturer's instructions and be undertaken by suitably qualified personnel.
- d) Before working on a gearbox or associated equipment, ensure that the load has been removed from the system to eliminate the possibility of any movement of the machinery and isolate power supply. Where necessary, provide mechanical means to ensure the machinery cannot move or rotate. Ensure removal of such devices after work is complete.
- e) Ensure the proper maintenance of gearboxes in operation. Use only the correct tools and AB Benzlers approved spare parts for repair and maintenance. Consult the Maintenance Manual before dismantling or performing maintenance work.

8) Hot Surfaces and Lubricants

- a) During operation, gear units may become sufficiently hot to cause skin burns. Care must be taken to avoid accidental contact.
- b) After extended running the lubricant in gear units and lubrication systems may reach temperatures sufficient to cause burns.
Allow equipment to cool before servicing or performing adjustments.

9) Selection and Design

- a) Where gear units provide a backstop facility, ensure that back-up systems are provided if failure of the backstop device would endanger personnel or result in damage.
- b) The driving and driven equipment must be correctly selected to ensure that the complete machinery installation will perform satisfactorily, avoiding system critical speeds, system torsional vibration, etc.
- c) The equipment must not be operated in an environment or at speeds, powers, and torques or with external loads beyond those for which it was designed.
Unintended use includes:
 - Overloading the gearbox or exceeding the limits that are defined in the technical data;
 - Converting or modifying the gearbox;
 - Using the gearbox for an application that it was not designed for.
- d) As improvements in design are being made continually the contents of this catalogue are not to be regarded as binding in detail, and drawings and capacities are subject to alterations without notice.

10) Waste Disposal

Waste (Used oil, Rubber items, Packing material etc) should be disposed as per local rules of disposal. The above guidance is based on the current state of knowledge and our best assessment of the potential hazards in the operation of the gear units.

Any further information or clarification required may be obtained by contacting AB Benzlers.

SERIES F

CONTENTS

SECTION	DESCRIPTION	PAGE No
1	Unit Identification _____	1
2	General Information _____	3
3	Fitting of Components to Shafts _____	3
4	Weather Protection of Unit _____	4
5	Installation	
5.1	Motorised and Reducers _____	4
5.2	Gearheads _____	4
5.3	Fixing to Customer Equipment _____	4
5.4	Motor Connections _____	4
5.5	Foot Mounted Units _____	5
5.6	Fitting Feet on Units _____	5
5.7	Shaft Mounted Units / Torque Bush Fixing _____	6
5.8	Replacement of Oil Seals _____	6
6	Lubrication and Maintenance	
6.1	Lubrication _____	7
6.2	Periodic Inspection _____	7
6.3	Lubricant Changes _____	7
6.4	Lubricant Quantity _____	7
6.5	Approved Lubricants _____	7
6.6	Approved Greases _____	7
7	Noise _____	7
8	Cleaning _____	7
APPENDIX		
1	Assembly of Motor and Motor Adaptor to the Gearhead _____	8
2	Lubricant Quantity _____	9 - 10
	Approved Lubricants _____	11 - 12
	Mounting Positions _____	13
3	Three Phase Induction Motor Installation _____	14
4	Approved Bearing Greases _____	15
5	Connection with the Driven Machine _____	16 - 17
6	Assembly onto Shaft - Customer Shaft Detail _____	18
	Disassembly method from shaft _____	19
	Alternative shaft fixing methods _____	20
7	Shrink Disc Mounting _____	21
	Part List _____	22 - 28

SERIES F INSTALLATION AND MAINTENANCE

1 UNIT IDENTIFICATION

Gearbox Codes														Motor Codes					
Series	Size of Unit		No of Reductions	Revision Version	Nominal Overall Ratio			Unit Version	Type of Unit	Output Shaft	Motor Adaptor	Mounting Position		Geared Motor Power	No of Motor Poles	Additional Motor Features	Additional Gearbox Features		
1	2	3	4	5	6	7	8	9	10	11	12	13	14	15	16	17	18	19	20
F	0	8	2	3	5	0	.	T	M	C	G	1	D	4	.	0	A	-	-

Example

- 1 - Series F
Range F
- 2, 3 - Size of Unit
0 2 - 1 0
- 4 - No of Reductions
2 - 4
- 5 - Revision Version
3
- 6, 7, 8 - Nominal Overall Ratio
e.g. 5 0 .
- 9 - Unit Version
STD with Torque Bush T
STD without Torque Bush W
STD with Output Flange F
- 10 - Type of Unit
M - Motorized with IEC standard motor
G - Unit to allow fitting of IEC motor (customer own motor)
R - Reducer unit
S - Reducer unit with fan kit
W - Reducer unit with backstop CCW rotation
X - Reducer unit with backstop CW rotation
Y - Reducer unit with fan and backstop CW rotation
Z - Reducer unit with fan and backstop CCW rotation

** Looking on Inputshaft Mounting Position 1 (See unit handings page)
*** Non Standard and Handing- Consult Application Engineering

20 - Additional Gearbox Features
Double Oil Seal, Motorized Backstop etc
e.g. - F

19 - Additional Motor Features
e.g. - A
For Types Without Motor Enter -

18 - No of Motor Poles
- No motor
50 Hz 60 Hz
4 Pole (Std) 1500 rpm A 1800 rpm B
4 Pole (High) 1500 rpm K 1800 rpm L
6 Pole (Std) 1000 rpm C 1200 rpm D
6 Pole (High) 1000 rpm M 1200 rpm N
2 Pole 3000 rpm E 3600 rpm F
8 Pole 750 rpm G 900 rpm H
S Dual speed or special motor

15, 16, 17 - Geared Motor Powers
Motor kW required
e.g. . 7 5
For reducer and non standard motor types enter - - -

13, 14 - Mounting Position
e.g. 2 B

12 - Motor Adaptor For Unit Types
Column 10 Entries M or G
See Pages 9 and 10
For All Other Types Enter -

11 - OUTPUT SHAFT
Standard Single Extension C
Standard Hollow Shaft H
Shrink Disc Y

* This Page May Be Photocopied Allowing The Customer To Enter Their Order

SERIES F

INSTALLATION AND MAINTENANCE

CE Ex Marking

These gear units are intended for use in industrial systems. The units are correctly installed in accordance with these instructions (gear units only) they comply with the ATEX Directive – 2014/34/EU.

Electric Motors, couplings or any other equipment fitted to the gear unit must be comply with ATEX Directive - 2014/34/EU. If the unit is supplied as a geared motor package, it is important to check the name plates of the gear unit and the motor (or any other equipment fitted) corresponds with the classification of the potentially explosive atmosphere in which the unit is to be installed. If the motor is earthed, electrical continuity is ensured by the adaptor between the motor and gearbox that is always of metallic material. It is the final responsibility of the installer to verify the electrical continuity between the engine and gearbox.

ATEX classification

Example		CE Ex	II	2	G	Ex h	IIB	T3 or T 125°C	Ga
Meaning	Variant	ATEX classification							
Classification	Conformity for European Directive	CE							
Classification	Explosion protection symbol	Ex							
Device Group	Above ground use		II						
Category	Zone 1, 21			2					
	Zone 2, 22			3					
Drive design	Explosive atmosphere caused by gas				G				
	Explosive atmosphere caused by dust				D				
Ignition protection	Constructional safety / liquid immersion					Ex h			
Explosion group :									
Area exposed to gases	High ignition power required						IIA		
	Medium ignition power required						IIB		
	Low ignition power required						IIC		
Area exposed to dust	Lint						IIIA		
	Non-conductive dust						IIIB		
	Conductive dust						IIIC		
Temperature class / temperature limits for the zones	450 C							T1	
	300 C							T2	
	200 C							T3	
	135 C							T4	
	100 C							T5	
	85 C							T6	
	e.g. Max. surface temperature 125 C.							T 125	
Equipment protection level	Very high protection level in gas								Ga
	High protection level in gas								Gb
	Normal protection level in gas								Gc
	Very high protection level in dust								Da
	High protection level in dust								Db
	Normal protection level dust								Dc

SERIES F INSTALLATION AND MAINTENANCE

2 GENERAL INFORMATION

The following instructions will help you achieve a satisfactory installation of your Power Build Pvt Ltd Series F unit, ensuring the best possible conditions for a long and trouble free operation.

All units are tested and checked prior to despatch, a great deal of care is taken in packing and shipping arrangements to ensure that the unit arrives at the customer in the approved condition.

3 FITTING OF COMPONENTS TO EITHER THE UNIT INPUT OR OUTPUT SHAFT

The input or output shaft extension diameter tolerance is to ISO tolerance k6 (for shaft diameter $\leq 50\text{mm}$) and m6 (for shaft diameter $> 50\text{mm}$) and the fitted components should be to ISO tolerance M7 (for bore diameter $\leq 50\text{mm}$) and K7 (for bore diameter $> 50\text{mm}$).

- Items (such as gears, sprockets, couplings etc) should not be hammered onto these shafts since this would damage the shaft support bearings.
- The item should be pushed onto the shaft using a screw jack device fitted into the threaded hole provided in the end of the shaft.
- Items being fitted may be heated to 80/100°C to aid assembly further.

THREADED HOLE DETAILS

UNIT SIZE	INPUT SHAFT	OUTPUT SHAFT
F0223/F0233/F0323/F0333 F0423 / F0433	M5 x 12.5 mm deep	M10 x 22 mm deep
F0523/F0623	M6 x 16 mm deep	M16 x 36 mm deep
F0533/F0633	M5 x 12.5 mm deep	
F0723	M8 x 19 mm deep	M16 x 36 mm deep
F0733	M6 x 16 mm deep	
F0823	M10 x 22 mm deep	M20 x 42 mm deep
F0833	M8 x 19 mm deep	
F0923	M12 x 28 mm deep	M20 x 42 mm Deep
F0933	M10 x 22 mm deep	
F1023	M16 x 2.00 x 36 mm	M24 x 3.00 x 50 mm
F1033	M12 x 1.75 x 28 mm	
F1424	M20 x 2.50 x 42 mm	
F1434	M16 x 2.00 x 36 mm	
F2524	M20 x 2.50 x 42 mm	M30 x 3.50 x 60 mm
F2534	M16 x 2.00 x 36 mm	

SERIES F

INSTALLATION AND MAINTENANCE

4 WEATHER PROTECTION OF UNIT

All Series F units are provided with protection against normal weather conditions. Where units are to operate in extreme conditions, or where they are to stand for long periods without running, eg during plant construction, we should be notified when ordering so that arrangements for adequate protection can be made.

5 INSTALLATION

5.1 MOTORISED AND REDUCERS

- Sizes F02, F03, F04, F05, F06 and F07 are supplied factory filled with correct amount of lubricant for mounting position quoted (Factory fill - Power Build Pvt Ltd).
- Sizes F08, F09, F10, F14 & F25 will be oil filled by client.
If the unit is to be mounted in a different position to that originally intended then the amount of lubricant in the unit will require amending
 - See Appendix 2 of this document for the revised quantities
 - See Appendix 1 for the methodology for doing this.

NOTE: It is important that the same oil is used as is already in the unit.

If an oil other than that in the unit is to be used the unit should be drained and flushed with the oil to be used and filled with the correct quantity.

5.2 GEAR HEADS

If the unit has been supplied as a Gear Head type to allow fitting of the motor separately then refer to Appendix 1. For sizes F02, F03, F04, F05, F06 & F07 only, units satisfying condition 'G' (ref Appendix 1) will be supplied filled with oil, and units satisfying condition 'A' or 'M' (ref Appendix 1) will be supplied less oil.

5.3 FIXING TO CUSTOMER EQUIPMENT

Fixing the Gear Head flange facing, or feet to the customer equipment use set screws to ISO grade 10.9 minimum.

Torque tighten to:-

Set Screw Size	Tightening Torque
M6	10 Nm
M8	25 Nm
M10	50 Nm
M12	85 Nm
M16	200 Nm
M20	350 Nm
M24	610 Nm
M30	1220 Nm
M36	2150 Nm

5.4 MOTOR CONNECTIONS

TO MAINS

Connection of the electric motor to the mains supply should be made by a qualified person. The current rating of the motor will be identified on the motor plate, and correct sizing of the cables to electrical regulations is essential.

MOTOR TERMINAL CONNECTION

Circuit diagrams for the correct wiring of the motor terminal box are included as Appendix 3

SERIES F INSTALLATION AND MAINTENANCE

5.5 FOOT-MOUNTED UNITS

The following procedure is recommended for all foot mounted units.

Foot mounted units are supplied either as free standing units, or if required, mounted on a standard baseplate with a foot mounted motor correctly aligned and connected by a flexible coupling.

- a) Clean shaft extensions and ventilator when fitted.
- b) Secure unit, or baseplate if fitted to a rigid foundation using heavy duty bolts to ISO grade 8.8 minimum.
- c) Ensure baseplate is not distorted
Note: Units not supplied on baseplates should if possible be mounted on the same bedplate as the prime mover.
- d) Align unit (see Appendix 5)
Note: It is important to ensure when aligning unit on baseplate that all machined mounting points are supported over their full area.
If steel packings are used these should be placed either side of the foundation bolt as close as possible. During the final bolting ensure the unit or baseplate is not distorted this will cause strains in the gear case resulting in errors of alignment of shafts and gearing.
- e) For units mounted on bedplates after alignment select any two diagonally opposite feet, drill ream and dowel in position.
- f) Fit guards in accordance with the factory acts.
- g) Check motor wiring for correct direction of rotation this is important when a backstop device is fitted.
- h) Fill gear unit with oil (if not factory filled) as detailed in Section 6.

5.6 FITTING FEET ON UNITS

Series F units are fitted with detachable feet. These are normally factory fitted to clients specification, but if for any reason the feet are supplied separately, or dismantling is necessary after supply, they should be re-fitted and torque tightened to the following settings.

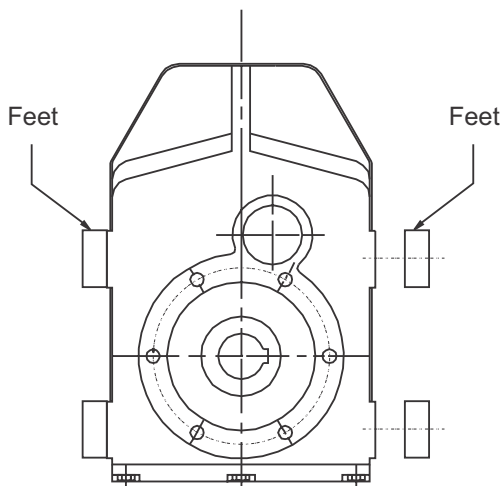

ALL SIZES

- Scrape any paint etc off foot location faces on casing.
- Clean feet and case fixing faces with Lowtox or Loctite 7061.
- Fit feet with setscrews to torques:

Unit Size	Bolt Size	Torque
F04	M10	50 Nm
F06	M12	85 Nm
F07, F08, F09	M16	200 Nm
F10	M20	350 Nm
F14	M24	610 Nm
F25	M30	1220 Nm

DANGER

- The installation of the gearbox onto/into the customer machine must be made in such a way that no clearances may develop where dust can deposit which may come into contact with moving parts (risk of heat development).
- A change in mounting position may only be carried out after consultation with PBPL. The ATEX approval no longer applies when PBPL is not consulted!
- The gearboxes/geared motors must not be used in systems with cathodic protection!
- The gearboxes and motors must be included in the equipotential bonding of the system.
- Placing an installation above hot parts on which, for instance, leaking oil may ignite is not permissible. If required, install an oil collecting trough.

SERIES F INSTALLATION AND MAINTENANCE

5.7 SHAFT MOUNTED UNITS

The following procedure is recommended for all shaft and foot/shaft mounted units.

- a) Clean shaft extensions, bore and ventilator when fitted.
- b) Locate in position, using the most convenient method available see Appendix 6, ensuring it is as close as possible to the bearing on the driven machine.
- c) Secure unit onto the shaft using chosen method from Appendix 6.
- d) Fit torque bush as detailed below.

Note: Unless specified otherwise, the torque bush will be supplied loose.

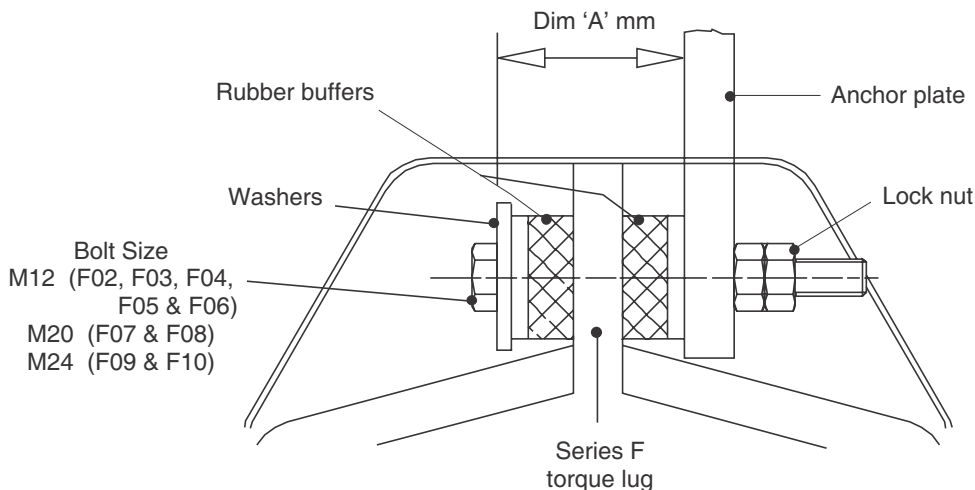

Unit Size	Dim 'A' mm
F02	54
F03	56
F04	54
F05	58
F06	60
F07	106
F08	112
F09	142
F10	148
F14	210
F25	255

- Notes
- 1) Tighten bolt to give Dim 'A' this will pre compress the rubber buffers
 - 2) Power Build Pvt Ltd Torque arm kit comprises two rubber buffers. The customer must supply other components shown.

- e) Anchor case to a secure point by means of the torque bush.
- f) Fit guards in accordance with the factory acts.
- g) Check motor wiring for correct direction of rotation, this is important when a backstop device is fitted.
- h) Fill gear unit with oil (if not factory filled) as detailed in Section 5.

5.8 REPLACEMENT OF OIL SEALS

- a. Clean and drain the unit.
- b. If the unit has an output shaft then remove any equipment from the outputshaft such as couplings and remove the output key. If the unit is Shaft Mounted then remove the unit from the shaft.
- c. Remove the old seal.
- d. Smear oil seals with grease (see Appendix 4).
- e. Fit replacement seal on a seal guide, slide it along the shaft and press the seal into the housing.
- f. Fill with the correct amount of approved lubricant, see Appendix 2

SERIES F INSTALLATION AND MAINTENANCE

6 LUBRICATION AND MAINTENANCE

6.1 LUBRICATION

- Unit sizes F02, F03, F04, F05, F06 and F07 are factory filled with mineral oil.
- Unit sizes F08, F09, F10, F14 & F25 will be oil filled by client. (See Appendix 2).

6.2 PERIODIC INSPECTION

- a. Check oil level every 3000 hours or 6 months whichever is sooner and if necessary top up with the recommended grade of lubricant.
- b. Add two shots of grease monthly to units having grease lubricated bearings.

6.3 OIL CHANGES

On all sizes regular oil changes are essential and the following factors should be used to determine the frequency at which these are carried out.

- a. Oil temperature - unit operating under load.
- b. Type of oil.
- c. Environment - humidity, dust, etc.
- d. Operating conditions - shock, loading, etc.

At elevated temperatures the effective life of the oil is very much reduced. This is most pronounced with oils containing fatty and E.P. additives. To prevent damage to the unit through lubricant breakdown the oil should be renewed as detailed in the following table:

UNIT OPERATING TEMPERATURE °C	RENEWAL PERIOD	
	MINERAL OIL	SYNTHETIC OIL
75 OR LESS	17000 HOURS OR 3 YEARS	26000 HOURS OR 3 YEARS
80	12000 HOURS OR 3 YEARS	26000 HOURS OR 3 YEARS
85	8500 HOURS OR 3 YEARS	21000 HOURS OR 3 YEARS
90	6000 HOURS OR 2 YEARS	15000 HOURS OR 3 YEARS
95	4200 HOURS OR 17 MONTHS	10500 HOURS OR 3 YEARS
100	3000 HOURS OR 12 MONTHS	7500 HOURS OR 2 1/2 YEARS
105	2100 HOURS OR 8 MONTHS	6200 HOURS OR 2 YEARS
110	1500 HOURS OR 6 MONTHS	5200 HOURS OR 18 MONTHS

NB: INITIAL FILL OF OIL SHOULD BE CHANGED IN A NEW GEAR UNIT AFTER 1000 HOURS OPERATION OR ONE YEAR OR HALF THE ABOVE LIFE WHICHEVER IS THE SOONEST

Note: Figures quoted are for oil temperatures when the unit has attained normal running temperature when operating under load. These figures are based on normal running but where conditions are particularly severe it may be necessary to change the oil more frequently. When changing lubricant, if same lubricant is not used then unit must be flushed out and filled only with one type of lubricant.

6.4 LUBRICANT QUANTITY

The quantity of lubricant required by size and mounting position is given in Table 1, Appendix 2. A diagram showing mounting position designations is also included in Appendix 2.

6.5 APPROVED LUBRICANTS

Tables 2 and 3 Appendix 2 give the lubricants approved for use in the gear unit.

6.6 GREASE LUBRICATION

Where re-greasing points are provided add 2 shots (6 grams) monthly of NLGI 2 grade grease. Appendix 4 gives the grease approved for use in the unit.

7 NOISE

The range of Series F product satisfies a noise (sound pressure level) of 85 dB(A) or less when measured at 1 metre from the unit surface.

Measurements taken in accordance with B.S.7676 Pt1 : 1993 (ISO 8579-1 : 1993).

8 CLEANING

With the drive stationary periodically clean any dirt or dust from the gear unit and the electric motor cooling fins and fan guard to aid cooling.

The breather plug should be checked for blockage of hole and it is required to clean if required.

Any further information or clarification required may be obtained by contacting P_{AB} Benzlers.

Please see contact details at the back of this booklet.

ASSEMBLY OF MOTOR AND MOTOR ADAPTOR TO THE GEAR HEAD

Depending on motor frame size and type of flange facing (C or D flange) determines whether or not the motor adaptor is attached firstly to the motor or to the Gear Head.

		F0223/F0233/F0323/F0333 F0423 / F0433		F0623/0733		F0723/F0833	
MOTOR FLANGE	MOTOR FRAME	C (B14)	D (B5)	C (B14)	D (B5)	C (B14)	D (B5)
63		N/A	A				
71		M	G	M	G		
80		M	G	M	G	M	G
90		G	G	M	G	M	G
100 / 112		G	G	M	G	M	G
132				G	G	M	G
160							G

	F08, F09, F10, F14 & F25
ALL MOTOR FRAME SIZES	G

- A - Adaptor sandwiched between motor and Gear Head
- M - Fix adaptor to motor then fix assembly to Gear Head
- G - Fix adaptor to Gear Head first then fit motor
- N/A - Not available

- Note: (Re Sizes F04 to F07)
- For build condition 'A' and 'M' only, prior to fitting the motor adaptor, fill the gearcase with the correct amount of lubricant (Appendix 2). Apply liquid gasket material (Loctite 518) to the upturned face of the gearhead in a continuous bead. The gasket material should be outside any leak path and all screw holes should be ringed. (Health and Safety instructions with the material must be observed).
 - When fitting the motor adaptor to the electric motor for build condition 'M', ensure that the copper washers supplied with the kit are fitted under the heads of the set screws fixing the adaptor to the motor.

SET SCREW TORQUES:-

SET SCREW SIZES	RECOMMENDED TORQUE
M6	10 Nm
M8	18 Nm
M10	37 Nm
M12	64 Nm
M16	150 Nm

SERIES F

APPENDIX 2

LUBRICATION

Lubrication

- F02 to F07** are supplied factory filled with a quantity of EP mineral oil (Grade 7E) appropriate to the mounting position. If the gear unit is drained for any reason it must be re-filled with the correct grade and quantity of lubricant as shown in the table below.
- F08 to F10, F14 & F25** are supplied without lubricant and must be filled via the ventilator position with EP mineral oil (Grade 7E) until oil escapes through the level plug hole – see table below for the approximate quantity of lubricant.

Maintenance:

- F02 to F07**, These units must be fully drained and refilled with the correct quantity of lubricant.
 - F08 to F10, F14 & F25** The Lubricant levels can be checked and maintained by filling through the fill/ventilator position until oil escapes through the level plug hole - See Mounting Positions and Lubricant Fill Levels on the adjacent page.
- F02 to F07 units, do not require a ventilator.
F08 to F10, F14 & F25 units only, fit the ventilator plug in the position appropriate to the mounting position.
 - Quadruple Reduction Units consist of a smaller Series M primary unit flange mounted onto the main Series F unit, see Series M lubrication data for details appropriate to the primary unit, both units should be checked for oil type and quantity.

Lubricant quantities are approximate for F08 to F10, F14 to F25 fill until oil escapes from the level plug hole

Temperature Limitations

The standard lubricant is suitable for operation in ambient temperatures of 0° to 50°C, outside of this consult Table 1 or consult Application Engineering.

Table 1 Oil Grades

Lubricant	Ambient temperature range		
	-5°C - 20°C (E) -30°C - 20°C (H)	0°C - 35°C	20°C - 50°C
EP Mineral Oil (type E)	5E (VG 220)	6E (VG 320)	7E (VG 460)
Polyalphaolefin based Synthetic (type H)	5H (VG 220)	5H (VG 220)	6H (VG 320)

Lubricant Quantities (Litres)

Double Reduction												
Size	F0223	F0323	F0423	F0523	F0623	F0723	F0823	F0923	F1023	F1424	F2524	
Mounting Position	1	0.80	1.20	2.10	3.20	4.90	9.20	12.1	20.3	37.0	18.0	70.8
	2	0.40	0.75	1.10	2.00	2.70	4.50	9.0	14.7	24.1	26.0	47.8
	3	0.40	1.10	1.20	2.30	3.00	5.30	11.0	18.6	31.5	31.5	61.7
	4	0.50	1.80	1.40	3.20	3.90	8.80	10.5	15.9	28.8	29.5	56.2
	5	1.10	1.20	2.00	3.00	3.90	7.50	18.1	25.3	49.0	42.3	81.3
	6	1.30	1.50	2.10	4.40	5.90	8.80	15.8	25.8	47.3	50.3	89.0

Triple Reduction												
Size	F0233	F0333	F0433	F0533	F0633	F0733	F0833	F0933	F1033	F1434	F2534	
Mounting Position	1	0.80	1.20	2.10	3.20	4.90	9.20	11.7	21.0	37.0	36.1	72.2
	2	0.40	0.75	1.10	2.30	2.50	4.20	8.6	14.0	23.3	27.1	47.8
	3	0.40	1.00	1.20	2.30	3.00	5.30	10.0	17.0	33.3	32.5	58.8
	4	0.50	1.85	1.30	3.00	4.40	8.50	10.0	16.8	29.8	30.0	58.8
	5	1.10	1.20	2.00	3.00	3.80	7.20	17.4	24.2	46.5	37.8	85.2
	6	1.30	1.50	2.20	4.20	5.70	8.50	16.3	26.0	48.3	48.2	87.1

SERIES F

APPENDIX 2

LUBRICATION

Quadruple Reduction									
Size	F0343		F0443		F0543		F0643		
	Primary	Secondary	Primary	Secondary	Primary	Secondary	Primary	Secondary	
	M0122	F0323	M0122	F0423	M0322	F0523	M0322	F0623	
Mounting Position	1	0.50	1.20	0.50	1.70	0.80	2.30	0.80	4.70
	2	0.80	0.60	0.80	1.10	1.20	1.80	1.20	2.50
	3	0.60	0.60	0.60	1.40	0.70	1.80	0.70	3.90
	4	0.80	0.75	0.80	1.20	1.20	2.00	1.20	2.60
	5	0.70	1.20	0.70	2.80	1.10	2.80	1.10	3.90
	6	1.00	1.50	1.00	2.10	1.40	3.20	1.40	5.00

Quadruple Reduction									
Size	F0743		F0843		F0943		F1043		
	Primary	Secondary	Primary	Secondary	Primary	Secondary	Primary	Secondary	
	M0322	F0723	M0522	F0823	M0522	F0923	M0722	F1023	
Mounting Position	1	0.80	8.50	1.50	12.1	1.50	20.3	2.60	37.0
	2	1.20	4.50	1.80	9.0	1.80	14.7	2.90	24.1
	3	0.70	7.50	1.60	11.0	1.60	18.6	2.70	31.5
	4	1.20	7.50	1.80	10.5	1.80	15.9	3.00	28.8
	5	1.10	7.50	2.00	18.1	2.00	25.3	3.20	49.0
	6	1.40	8.50	2.60	15.8	2.60	25.8	4.70	47.3

SERIES F

APPENDIX 2

APPROVED LUBRICANTS

TABLE 2 MINERAL OILS

Type E - Mineral oils containing industrial EP additives. These have a high load carrying capacity

SUPPLIER	LUBRICANT RANGE	GRADE NUMBERS		
		5E	6E	7E
Batoyle Freedom	Remus	220 (-2)	320 (-2)	460 (-2)
Boxer Services / Millers Oils	Indus	220 (-10)	320 (-10)	460 (-10)
BP Oil International Limited	Energol GR-XF	220 (-16)	320 (-13)	460 (-1)
	Energol GR-XP	220 (-15)	320 (-10)	460 (-7)
Caltex	Meropa	220 (-4)	320 (-4)	460 (-4)
	RPM Borate EP Lubricant	220 (-7)	320 (-4)	460 (-7)
Carl Bechem GmbH	Berugear GS BM	220 (-20)	320 (-13)	460 (-10)
	Staroil G	220 (-13)	320 (-13)	460 (-10)
Castrol International	Alpha Max	220 (-19)	320 (-13)	460 (-10)
	Alpha SP	220 (-16)	320 (-16)	460 (-1)
Chevron International Oil Company Limited	Gear Comp EP (USA ver)	220 (-16)	320 (-13)	460 (-10)
	Gear Comp EP (Eastern ver)	220 (-13)	320 (-13)	460 (-13)
	Ultra Gear	220 (-10)	320 (-7)	460 (-7)
Eko-Elda Abee	Eko Gearlub	220 (-13)	320 (-10)	460 (-1)
Engen Petroleum Limited	Gengear	220 (-15)	320 (-12)	460 (-3)
Esso/Exxon	Spartan EP	220 (-12)	320 (-12)	460 (-4)
Fuchs Lubricants	Powergear		P/Gear (-16)	M460 (-4)
	Renogear V	220EP (-13)	320EP (-4)	460EP (-4)
	Renogear WE	220 (-7)	320 (-4)	400 (-4)
	Renolin CLPF Super	6 (-13)	8 (-10)	10 (-10)
Klüber Lubrication	Klüberoil GEM1	220 (-5)	320 (-5)	460 (-5)
Kuwait Petroleum International	Q8 Goya	220 (-16)	320 (-13)	460 (-10)
Lubrication Engineers Inc.	Almasol Vari-Purpose Gear	607 (-18)	605 (-13)	608 (-10)
Mobil Oil Company Limited	Mobil gear 600 series	630 (-13)	632 (-13)	634 (-1)
	Mobil gear XMP	220 (-19)	320 (-13)	460 (-7)
Omega Manufacturing Division	Omega 690		85w/140 (-15)	
Optimal Ölwerke GmbH	Optigear BM	220 (-11)	320 (-10)	460 (-7)
	Optigear	220 (-18)	320 (-9)	460 (-7)
Pertamina (Indonesia)	Masri	220 (-4)	320 (-4)	460 (-7)
Petro-Canada	Ultima EP	220 (-22)	320 (-16)	460 (-10)
Rocol	Sapphire Hi-Torque	220 (-13)	320 (-13)	460 (-13)
Sasol Oil (Pty) Limited	Cobalt	220 (-4)	320 (-1)	460 (-4)
	Hemat	220 (-10)	320 (-7)	460 (-4)
Saudi Arabian Lubr. Oil Co.	Gear Lube EP	EP220 (-1)	EP320 (0)	EP460 (0)
Shell Oils	Omala	220 (-4)	320 (-4)	460 (-4)
	Omala F	220 (-13)	320 (-10)	460 (-4)
Texaco Limited	Meropa	220 (-16)	320 (-16)	460 (-10)
	Meropa WM	220 (-19)	320 (-16)	460 (-11)
Total	Carter EP	220 (-21)	320 (-15)	460 (-12)
	Carter XEP	220 (-24)	320 (-18)	460 (-13)
Tribol GmbH	Molub-Alloy Gear Oil	90 (-18)	690 (-16)	140 (-13)
	Tribol 1100	220 (-20)	320 (-18)	460 (-16)
Hindustan Petroleum	HP PARTHAN EP	220 (-5)	320 (0)	460 (3)
Hindustan Petroleum	HP PARTHAN EP MA	220 (-6)	320 (-3)	460 (0)

THE UNIT MUST NOT BE RUN BELOW THIS TEMPERATURE.

SERIES F

APPENDIX 2

APPROVED LUBRICANTS

TABLE 3 SYNTHETIC OILS

Type H - Polyalphaolefin based synthetic lubricants with Anti-Wear or EP additives.
These have a medium to high load carrying capacity.

SUPPLIER	LUBRICANT RANGE	LUBRICATING OIL GRADE		
		5H	6H	7H
		AMBIENT TEMPERATURE RANGE °C		
		-30 to 10	-10 to 30	20 to 50
Batoyle Freedom Group	Titan	220 (-31)	320 (-28)	
Boxer Services / Millers Oils	Silkgear	220 (-35)	320 (-35)	460 (-35)
BP Oil International Limited	Enersyn EPX		320 (-28)	
Caltex	Pinnacle EP	220 (-43)	320 (-43)	460 (-37)
Carl Bechem GmbH	Berusrsynth GP	220 (-38)	320 (-35)	460 (-32)
Castrol International	Alphasyn EP	220 (-37)	320 (-31)	460 (-31)
	Alphasyn T	220 (-31)	320 (-28)	460 (-28)
Chevron International	Tegra	220 (-46)	320 (-33)	460 (-31)
Esso/Exxon	Spartan Synthetic EP	220 (-46)	320 (-43)	460 (-40)
Fuchs Lubricants	Renogear SG	220 (-32)	320 (-30)	
	Renolin Unisyn CLP	220 (-37)	320 (-34)	460 (-28)
Klüber Lubrication	Klübersynth GEM 4	220 (-30)	320 (-25)	460 (-30)
Kuwait Petroleum International	Q8 EL Greco	220 (-22)	320 (-19)	460 (-16)
Lubrication Engineers Inc	Synolec Gear Lubricant	9920 (-40)		
Mobil Oil Company Limited	Mobilgear SHC	220 (-40)	320 (-37)	460 (-32)
	Mobilgear SHC XMP	220 (-40)	320 (-33)	460 (-31)
Optimol Ölwerke GmbH	Optigear Synthetic A	220 (-31)	320 (-31)	
Petro-Canada	Super Gear Fluid	220 (-43)	320 (-37)	460 (-37)
Shell Oils	Omala HD	220 (-43)	320 (-40)	460 (-37)
Texaco Limited	Pinnacle EP	220 (-43)	320 (-43)	460 (-37)
	Pinnacle WM	220 (-43)	320 (-40)	
Total	Carter SP	220 (-34)	320 (-31)	460 (-28)
Tribol GmbH	Tribol 1510	220 (-36)	320 (-33)	460 (-28)
Hindustan Petroleum	HP PARTHAN SL	220 (-33)	320 (-30)	460 (-28)

DANGER

Numbers in brackets indicate recommended minimum operating temperature in °C.
THE UNIT MUST NOT RUN BELOW THIS TEMPERATURE.

SERIES F

APPENDIX 2

MOUNTING POSITION

MOUNTING 1

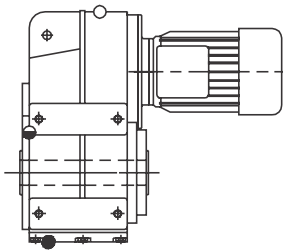

MOUNTING 2

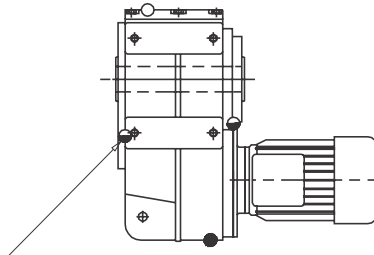

FILL TO PLUG AT THIS SIDE OF CASE FOR F08, F09 AND F10 UNITS

MOUNTING 3

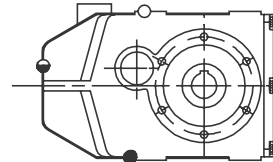

MOUNTING 4

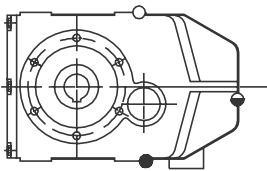

MOUNTING 5

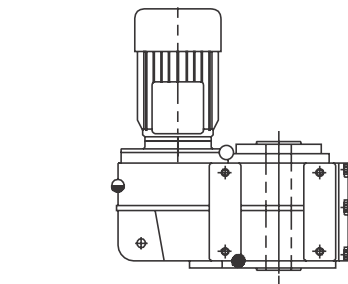

F0633/F0733 - OIL LEVELS TO HIGHER PLUG IN TRIPLE HOUSING

F0433 - NO OIL PLUGS IN TRIPLE HOUSING

MOUNTING 6

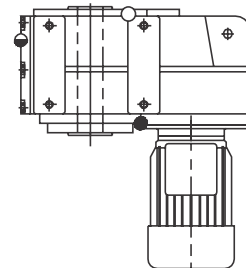

MOTOR MUST BE FITTED WITH SEAL FOR THIS POSITION

- DRAIN POSITION
- ◐ LEVEL POSITION
- VENTILATOR/FILLING POSITION

MOUNTING POSITIONS - SHOWN AS MOTORISED - APPLIES ALSO FOR REDUCERS

SERIES F

APPENDIX 3

THREE PHASE INDUCTION MOTOR

Connexion to Power System

All geared motors are factory-adjusted for maximum voltage if not stipulated otherwise. Make sure that the voltage on the installation site coincides with that indicated on the rating plate of the motor. The direction of rotation may be changed by interchanging two phases of the mains.

The geared motors are connected to the power supply system like any other three-phase A.C. Motors. There are no special instructions for Geared Motors beyond applicable for standard electric motors. The feed lines should be of sufficient diameter to avoid any notable drop of voltage upon starting the geared motors.

It is advisable to fit a protective motor switch with adjustable overload relays. This switch, which is adjusted to the motor rating, cuts out all three phases in case of overload or failure of one phase. The normal fuses can not give sufficient overload protection.

The connection diagram given below shows the usual types of connection of three phase A.C. Squirrel cage motors.

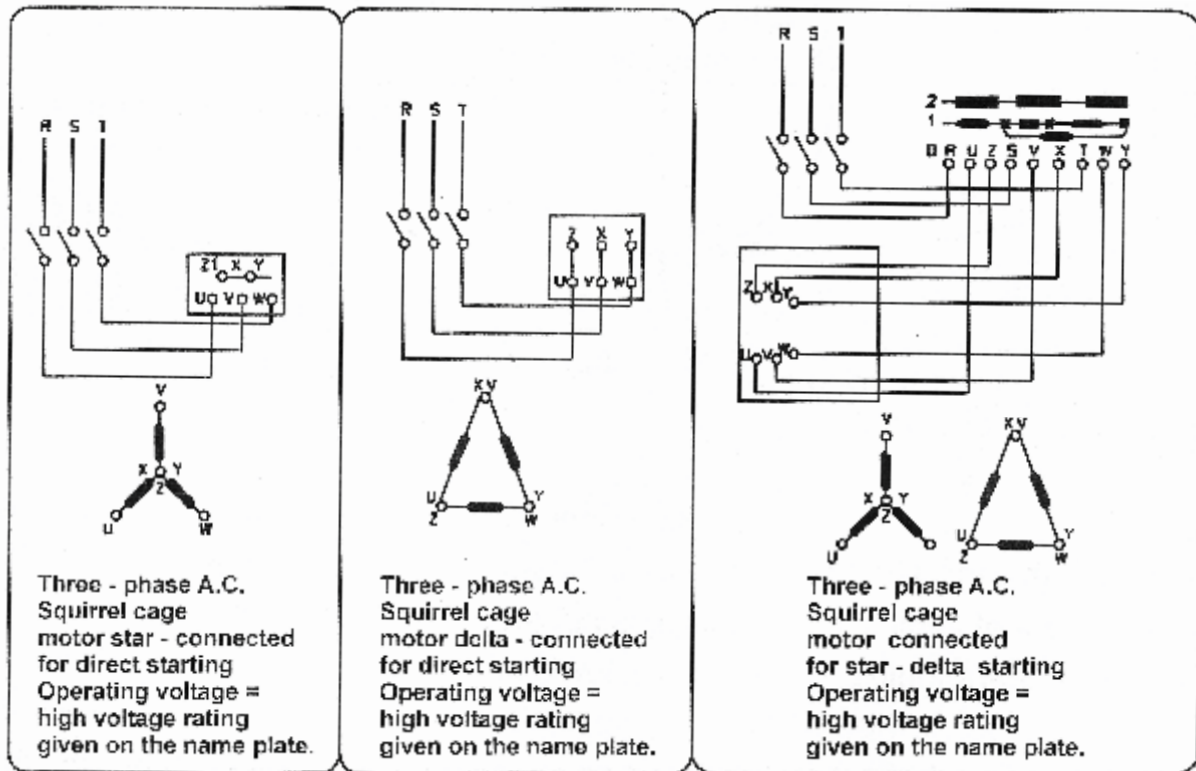

Geared Motors with pole and voltage changing system as well as motors for braking gears are provided with special connection diagrams which will be found on the inside of the terminal box of each motor.

STOP

- In frequency inverter operation, the motor must be provided with a corresponding ATEX approval.
- In frequency inverter operation in explosion group IIC, stray currents must be ruled out, since very low stray currents are already potentially explosive.

NOTE

- Please observe the operating instructions for the explosion-protected motor!.

DANGER

- The electric installation has to be carried out by skilled personnel in compliance with electro-technical regulations and standards.

SERIES F

APPENDIX 4

APPROVED BEARING GREASES

SUPPLIER	LUBRICANT RANGE	ALLOWABLE OPERATING TEMPERATURE RANGE °C	
		ABOVE	TO
BP Oil International Limited	Energrease LS-EP	-30	130
Caltex	Multifak EP	0	120
Castrol International	LMX Grease	-40	150
	Spheerol AP	-30	110
	Spheerol EPL	-10	120
Fuchs Lubricants	Renolit EP	-25	100
Klüber Lubrication	Klüberlub BE 41-542	-20	140
Mobil Oil Company Limited	Mobilgrease XHP	-15	150
	Mobilith SHC	-20	180
Omega Manufacturing Division	Omega 85	-40	230
Optimol Ölwerke GmbH	Longtime PD	-45	140
Shell Oils	Albida RL	-20	150
	Alvania EP B	-20	120
	Nerita HV	-30	130
Texaco Limited	Multifak All Purpose EP	-30	140

Notes:

- 1) All the above greases are NLGI grade 2.
- 2) Refer to Power Build Pvt Ltd Application Engineers if the unit is operating in an ambient temperature outside the range of -30°C to 50°C.

SERIES F

APPENDIX 5

CONNECTION WITH THE DRIVEN MACHINE

Connection with the Driven Machine

Since output shaft (low-speed shaft) and input shaft (high-speed shaft) are protected with rust preventive coating, remove it with thinner or a similar solvent.

1. Direct Connection

- (a) When the input shaft of the driven machine and the output shaft (low-speed shaft) of the geared motor/reducer are coupled directly, use a “flexible coupling” and make sure that both ends are in alignment. (Refer to Fig. 1.)

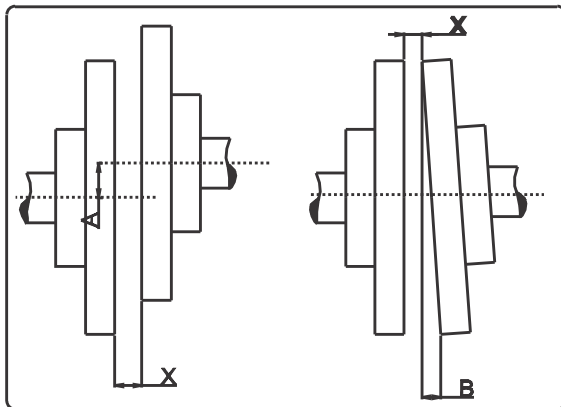

Allowance of Dimension A	0.05 mm
Allowance of Dimension B	0.04 mm
Dimension X	Specified by coupling maker

Fig. 1 Accuracy of alignment of direct coupling connection

2. When the machine is driven by V-belt, chain or gearing.

Make arrangement to ensure that the shaft of driven machine and that of geared motor/reducer is positioned parallel. When the machine is driven by V-belt or chain, ensure that the center distance is not too long by setting the proper distance and belt and chain are stretched at right angle. When the machine is driven by gearing, geared motor/reducer should be installed setting up the accurate center distance and avoiding partial bearing of gears, and the output shaft is pushed downward.

- (a) Point of load application on the output shaft :

When load (overhung load) is applied on the tip of the shaft, it may cause damage to the shaft. The gearing or chain sprocket wheel must be mounted such that the point of load application is as near as possible to the face of the unit to minimize overhung load.

- (b) Tension of chain:

When using chain, it is necessary to give suitable slack to chain. If the tension of chain is too loose, excessive shock will be generated at starting or load fluctuations, which may damage both the geared motor/reducer and the driven machine. Generally, the recommended amount of slack is 2% of span distance. (Refer to Fig. 2.)

CONNECTION WITH THE DRIVEN MACHINE

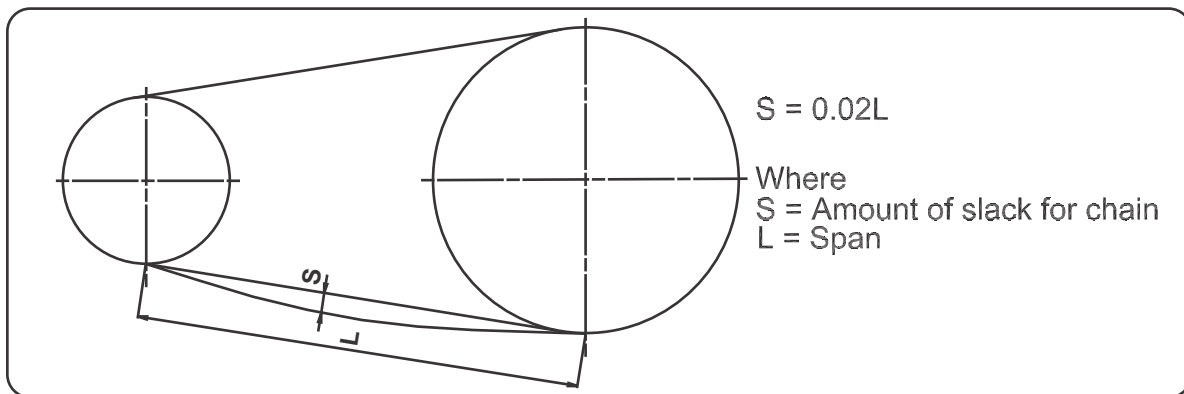

Fig. 2

(c) Layout of chain driving:

When using chain horizontally for connection with the drive and the driven machine, arrange shafts so as to give tension to the upper side of chain. Shaft arrangement of vertical transmission is not recommended, however, if necessary, the large wheel should be positioned at lower end.

(d) When load (overhung load) is applied on the output shaft, please make sure that it is within the limit of allowable value. Allowable value of overhung load is shown in graph of catalogue.

3. Dimension of keyway

Dimension of the shaft end keyway is in accordance with DIN 6885.

DANGER

- The assembly of the single components tested by ATEX must be checked for new ignition danger.
- The belt device is equipped with a pre-tension device.
- In explosion group IIC, no belt drives are permissible in category 2.

Assembly Onto Shaft - Customers Shaft Detail

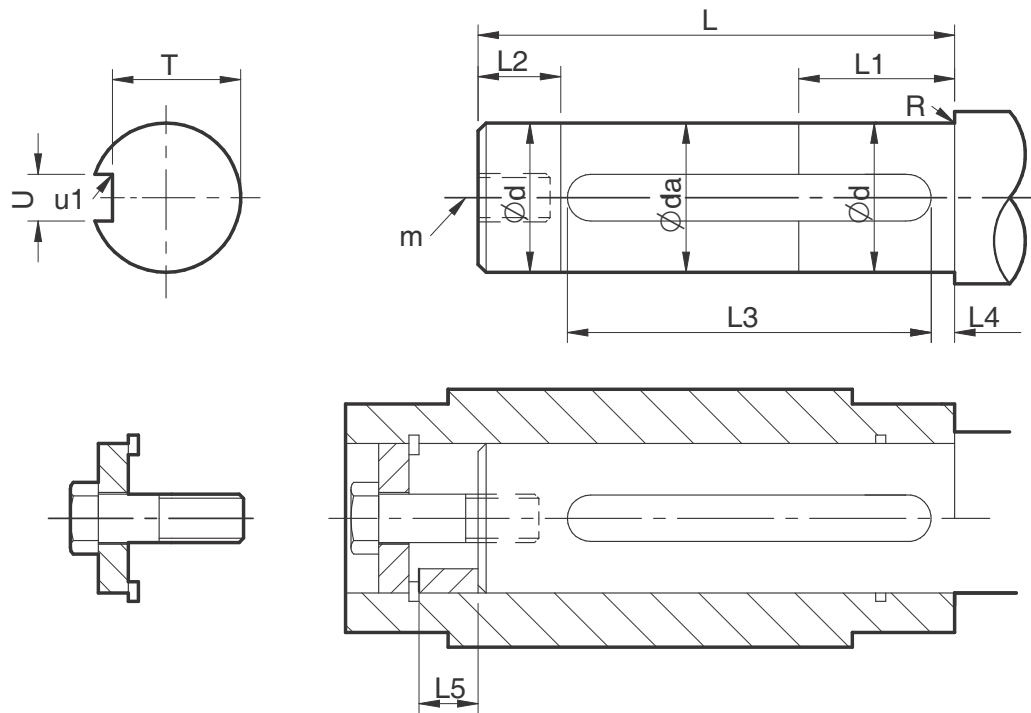

	d	da	L	L1	L2	L3	L4	L5	m	N	R	T	U	u1
F02	24.993/ 24.980	24.6	82	40	13	70.3 70.0	3	23	M10x1.5x22	15Nm	0.8R	21.0 20.8	8.000/ 7.964	0.16 0.25R
F03	29.993/ 29.980	29.6	82	45	15	70.3 70.0	3	23	M10x1.5x22	15Nm	0.8R	26.0 25.8	8.000/ 7.964	0.16 0.25R
F04	34.991/ 34.975	34.6	109	60	20	90.5 90.0	3	23	M12x1.75x30	20Nm	0.8R	30.0 29.8	10.000/ 9.964	0.16 0.25R
F05	39.991/ 39.975	39.6	112	60	20	92.5 92.0	3	30	M16x2x38	45Nm	0.8R	35.0 34.8	12.000/ 11.957	0.4 0.25R
F06	39.991/ 39.975	39.6	126	75	25	100.5 100.0	3	30	M16x2x38	45Nm	0.8R	35.0 34.8	12.000/ 11.957	0.4 0.25R
F07	49.991/ 49.975	49.6	153	90	30	130.5 130.0	3	30	M16x2x38	45Nm	0.8R	44.0 44.3	14.000/ 13.957	0.4 0.25R
F08	59.990/ 59.971	59.6	173	90	30	148.5 148.0	3	37	M20x2.5x42	85Nm	0.8R	53.0 52.8	18.000/ 17.957	0.4 0.25R
F09	69.991/ 69.975	69.6	232	105	35	161.5 161.0	3	38	M20x2.5x42	85Nm	0.8R	62.5 62.3	20.000/ 19.948	0.6 0.4R
F10	89.988/ 89.966	89.6	275	135	40	188.5 188.0	5	38	M24x3.0x50	200Nm	0.8R	81.0 80.8	25.000/ 24.948	0.6 0.4R
F14	99.988/ 99.966	99.0	290	120	44	260.5 260.0	15	38	M24x3.0x50	200Nm	0.8R	90.0 89.8	28.000/ 27.948	0.6 0.4R
F25	119.988/ 119.966	119.5	350	120	40	320.5 320.0	5	26	M24x3.0x50	200Nm	0.8R	109.0 108.8	32.000/ 31.938	0.6 0.4R

Assembly Instructions

1. Spray the hollow shaft bore and mating diameter of the output shaft with Rocol DFMS or equivalent anti-scuffing spray.
2. Fit key into shaft.
3. Fit the circlip into the output sleeve.
4. Fit the spacer tube only if the output shaft has no shoulder, then fit the output shaft into the output sleeve.
5. Secure in place with the washer and bolt. Torque tighten to the values stated in column N of the above table.

SERIES F

APPENDIX 6

STANDARD BORE DISASSEMBLY

Disassembly Method from Shaft

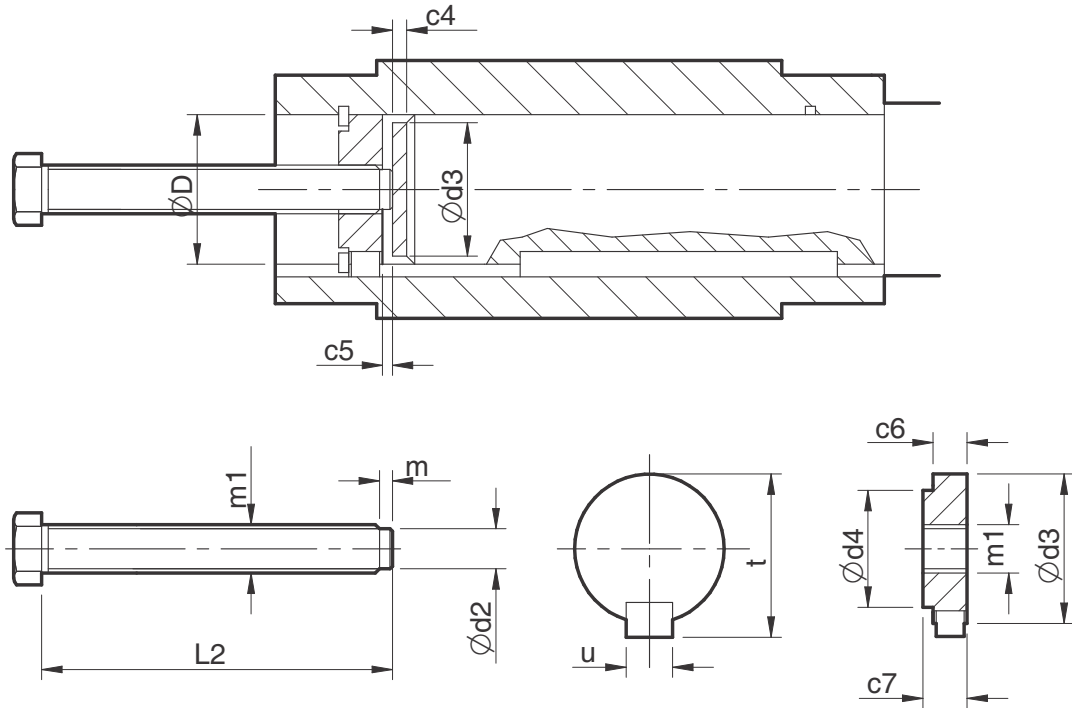

	c4	c5	c6	c7	D	d2	d3	d4	L2	m	m1	t	u
F02	5	3	15	17	25	10	24.9	16	120	3	M12 x 1.75	28	8
F03	5	3	15	17	30	13	29.9	20	130	3	M16 x 2.0	33	8
F04	5	3	15	17	35	13	34.9	25	160	3	M16 x 2.0	38	10
F05	5	4	20	23	40	20	39.9	29	190	3	M24 x 2.5	43	12
F06	5	4	20	23	40	20	39.9	29	190	3	M24 x 3.0	43	12
F07	5	4	20	23	50	20	49.9	39	220	3	M24 x 3.0	53.5	14
F08	8	5	24	27	60	25	59.9	47	250	5	M30 x 3.5	64	18
F09	8	6	24	27	70	25	69.9	53	310	5	M30 x 3.5	74.5	20
F10	8	6	24	27	90	25	89.9	72	360	5	M30 x 3.5	95	25
F14	8	3	27	35	100	30	99.9	80	420	5	M30 x 4.0	116	28
F25	8	3	15	30	120	30	119.9	96	520	5	M30 x 4.0	127	32

ALTERNATIVE SHAFT FIXING METHODS

SHAFT MOUNT UNITS

ALTERNATIVE SHAFT FIXING METHODS

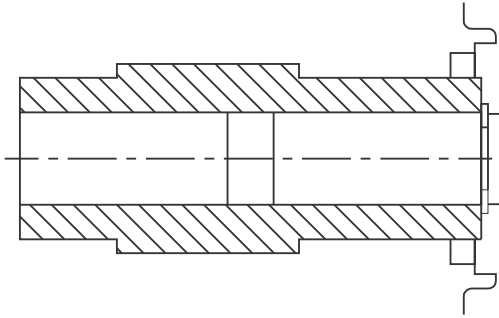

SHAFT MOUNT UNITS RETAINED WITH A CIRCLIP

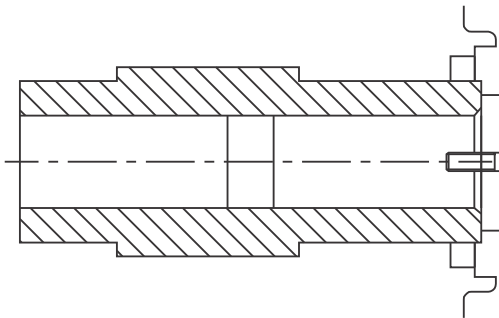

SHAFT MOUNT UNITS RETAINED WITH A BOLT AND PLATE

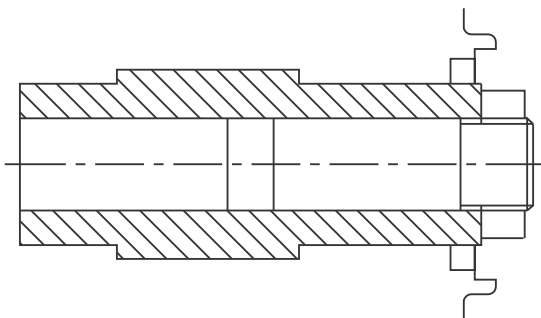

SHAFT MOUNT UNITS RETAINED WITH A LOCKNUT

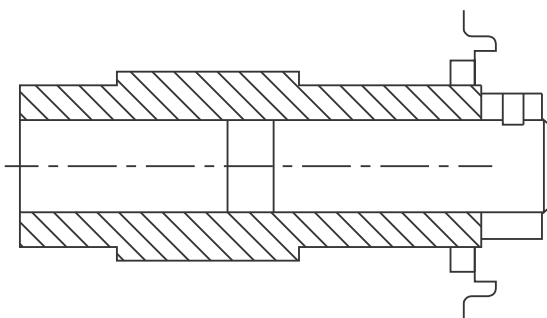

SHAFT MOUNT UNITS RETAINED WITH A COLLAR AND GRUBSCREW

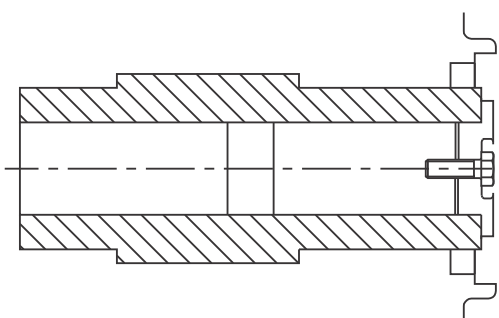

SHAFT MOUNT UNITS RETAINED WITH A RECESSED PLATE AND BOLT

SERIES F

APPENDIX 7

DIMENSIONS SHRINK DISC FITTING

Series F - with Shrink Disc

The Shrink Disc option requires a gear unit with a Shrink Disc type output bore, together with a Shrink Disc (A) locking device.

The Shrink Disc is a friction device (without keys) which exerts an external clamping force on the hollow gearbox shaft resulting in a mechanical shrink fit of the gear unit and driven shaft.

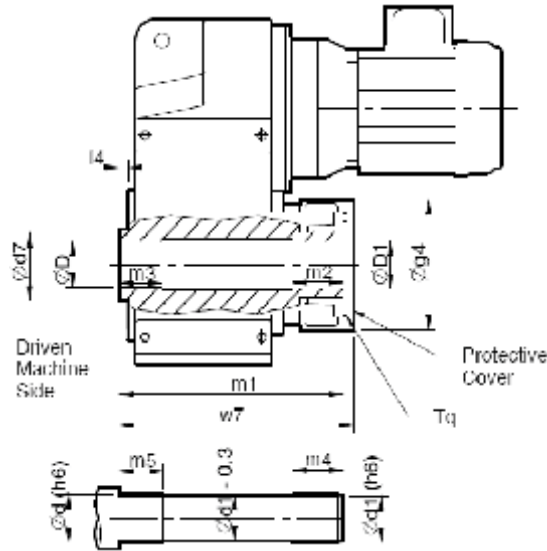

Dimensions (mm)

Size	D	D1	d (h6)	d1 (h6)	d7	f4	m1	m2	m3	m4 (min)	m5 (min)	g4	w7	Tq (Nm)
F04	35	35	35	35	50	3	177	32	20	37	25	-	-	29
F05	40	40	40	40	55	2	199	36	20	40	25	-	-	29
F06	40	40	40	40	70	2	230	38	40	40	25	105	241	29
F07	50	50	50	50	85	2	266	44	50	40	30	137	281	35
F08	65	65	65	65	90	3	305	45	50	45	40	150	315	58
F09	75	75	75	75	100	5	375	55	55	60	55	175	385	58
F10	95	95	95	95	120	5.5	425	65	62.5	76	70	210	442	100
F14	100	100	100	100	130	7	414	75	50	81	55	240	434	100
F25	120	120	120	120	160	10	498	92	60	98	65	325	519	250

Assembly

1. Clean and degrease the locating diameters of the gear unit hollow shaft bore, the driven shaft and the shrink disc locating surfaces.
2. Ensure the Anti-fret yellow metal bush(C) is correctly inserted in the non-driving end of the gear unit hollow shaft.
3. Draw the gear unit onto the driven shaft.
4. Check and re-apply if necessary MOLYKOTE 321R (or similar) to the tapered surfaces of the Shrink Disc inner ring and locking collar.
5. Fit the Shrink Disc inner ring and collar into position on the shaft, fit and tighten all the locking screws gradually in succession, do not tighten in a diametrically opposite sequence. This tightening sequence will require several passes until all the screws are tightened to the torque (Ta) specified in the table above.
6. Fit the protective cover where applicable.

Disassembly - Similar to the reverse of the assembly procedure.

1. Remove any rust and dirt from the assembly
2. Loosen off the locking screws in succession but do not completely remove.
3. Remove the shrink disc and withdraw the gear unit from the driven shaft.

NOTE: If the Shrink Disc is to be re-used, It should be dismantled and cleaned thoroughly and MOLYKOTE 321R (or similar) applied to the tapered surfaces of the inner ring and collar.

SERIES F

TWO STAGE GEARED MOTOR UNIT

F02-F10

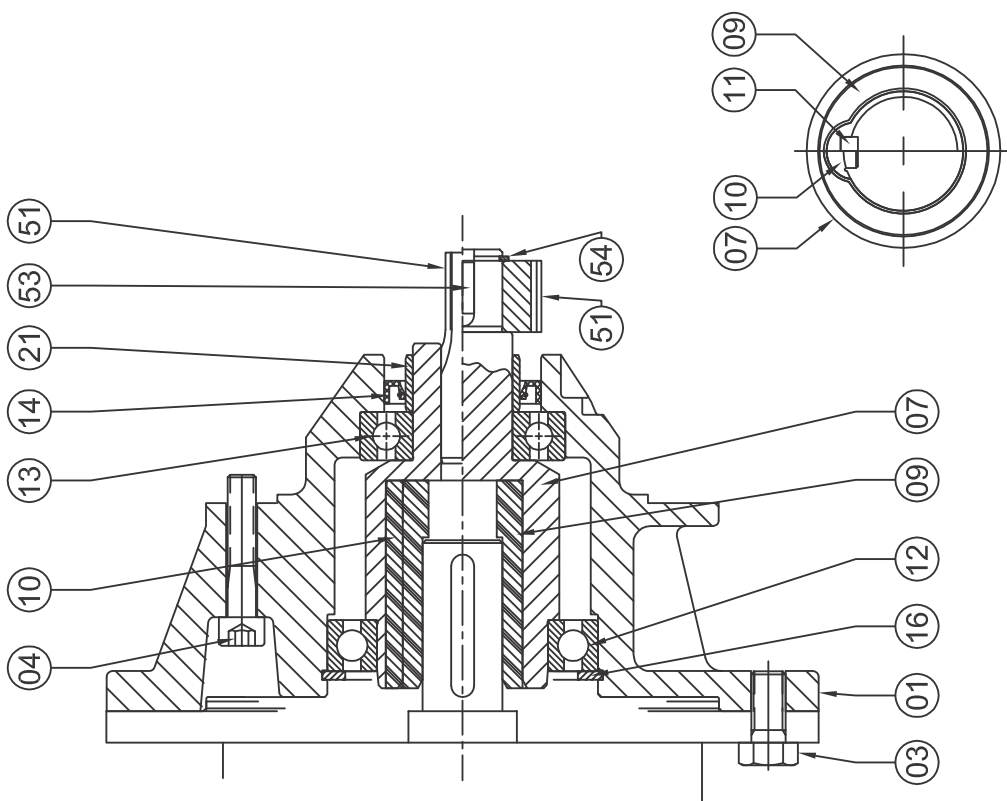
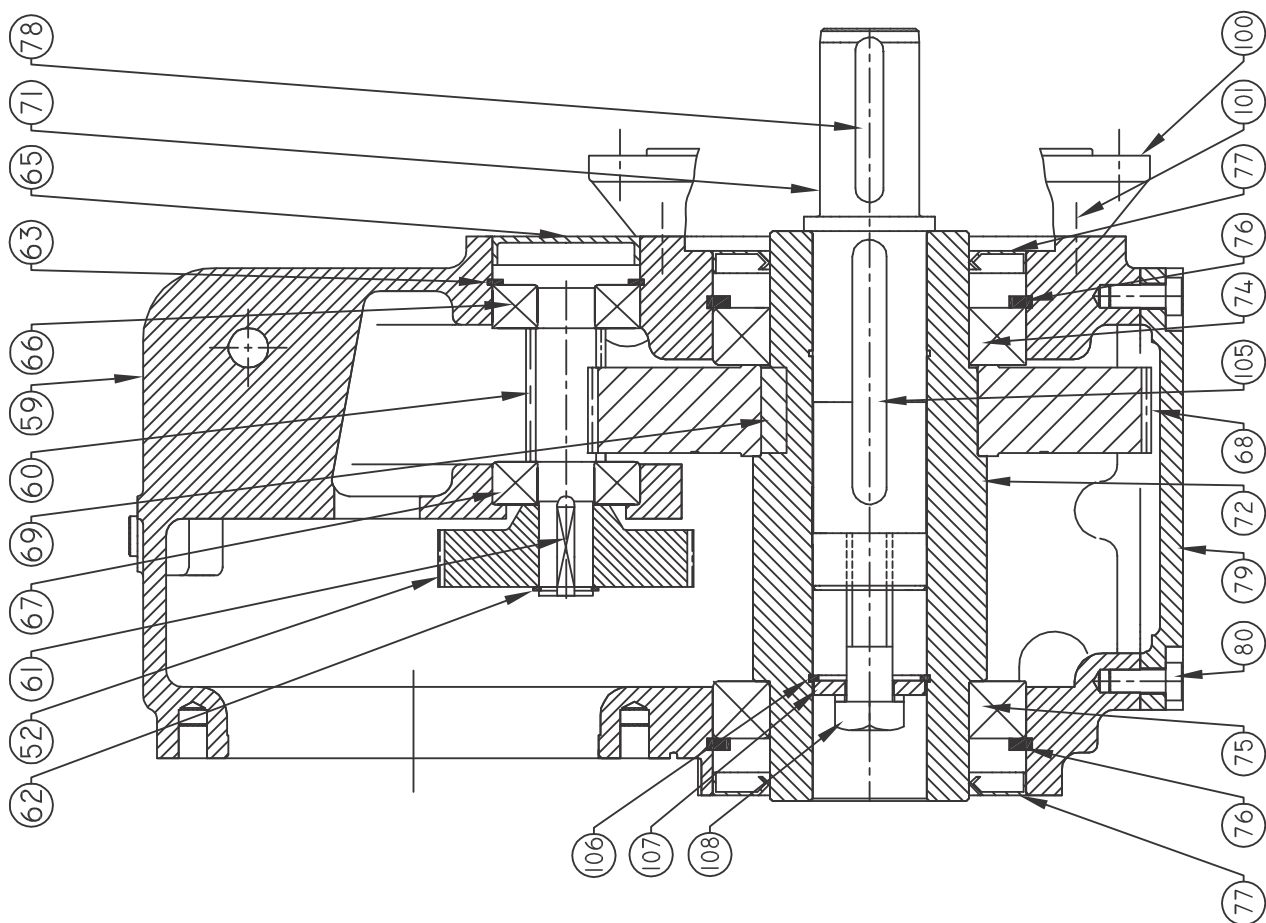

SERIES F

TWO STAGE GEARED MOTOR UNIT

F14-F25

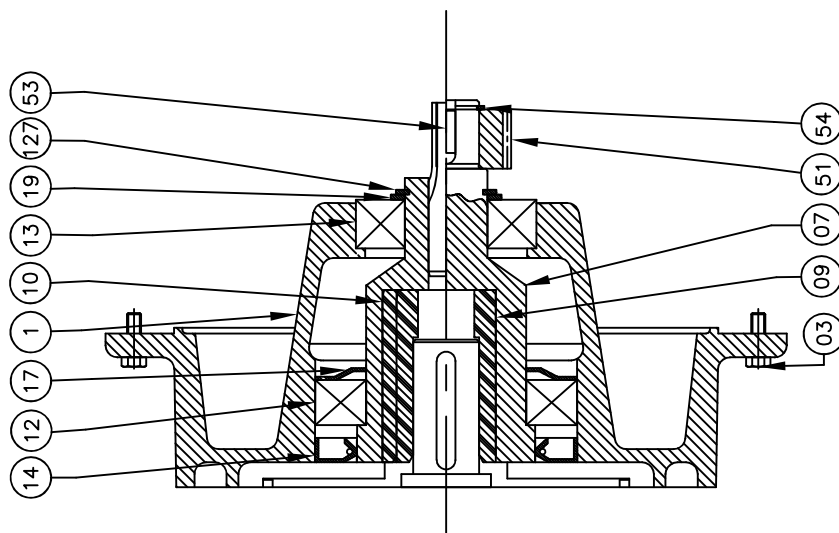
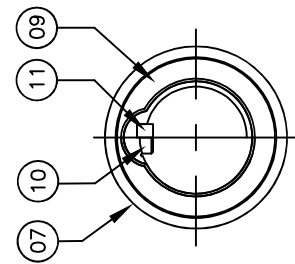
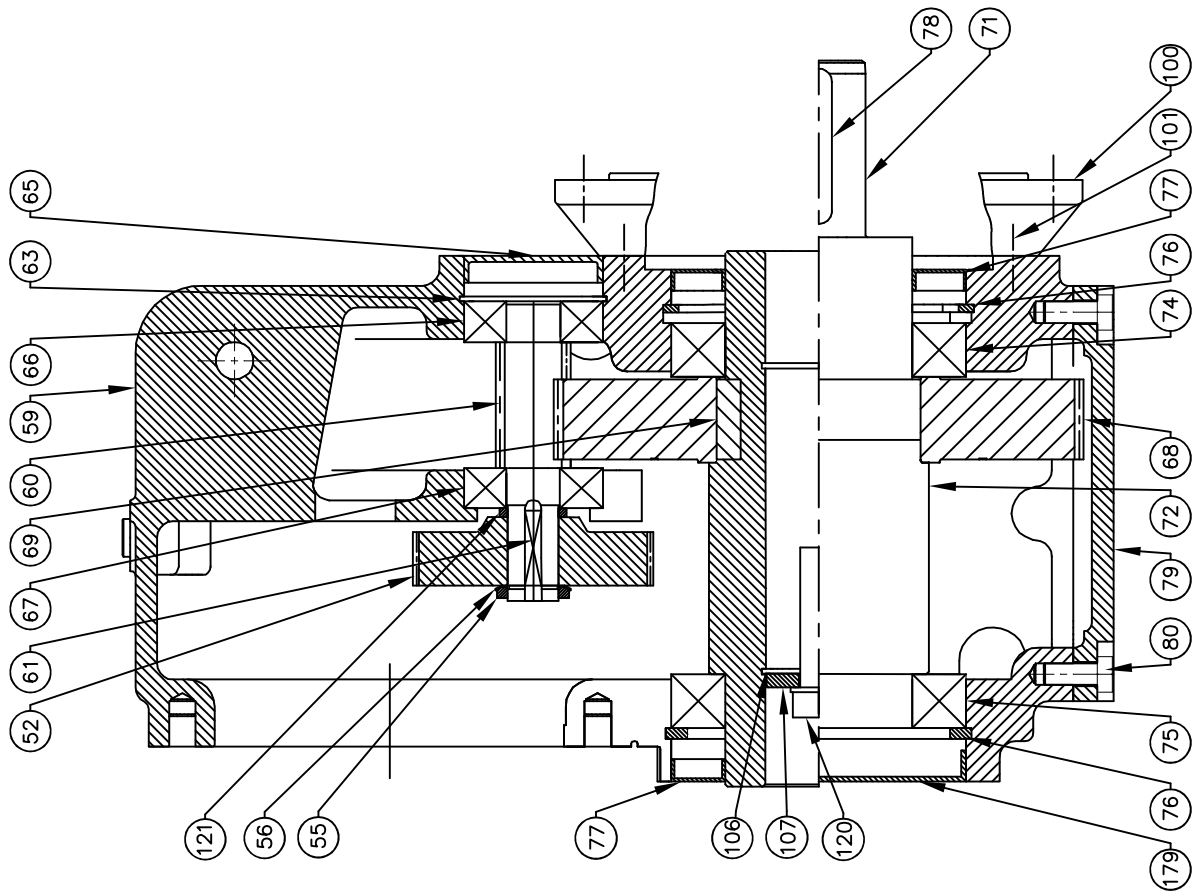

SERIES F

THREE STAGE GEARED MOTOR UNIT

F02-F10

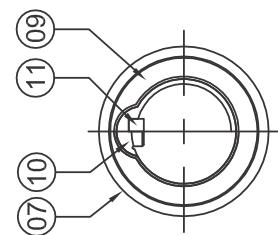
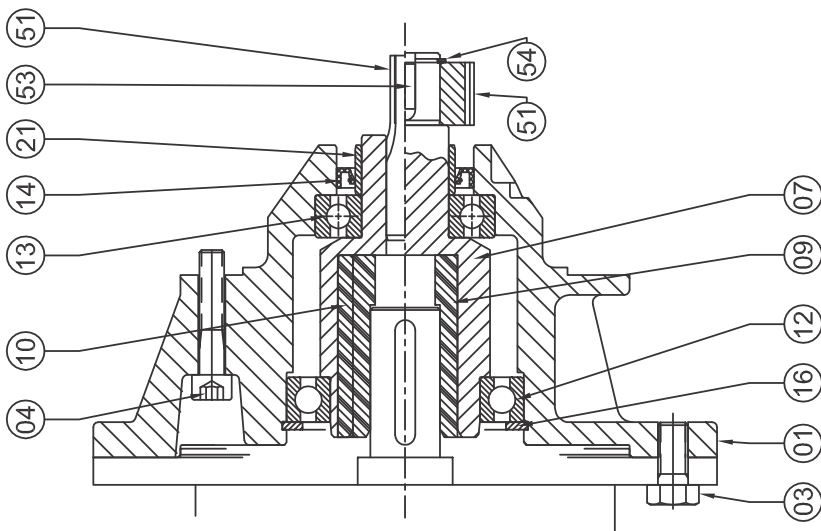
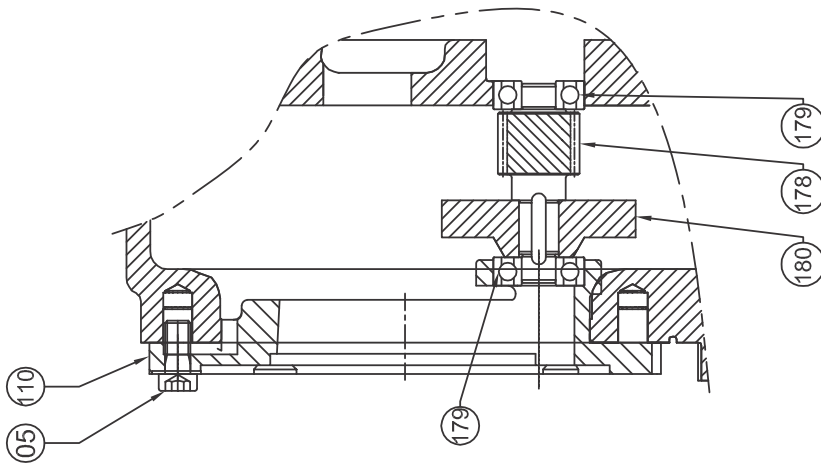
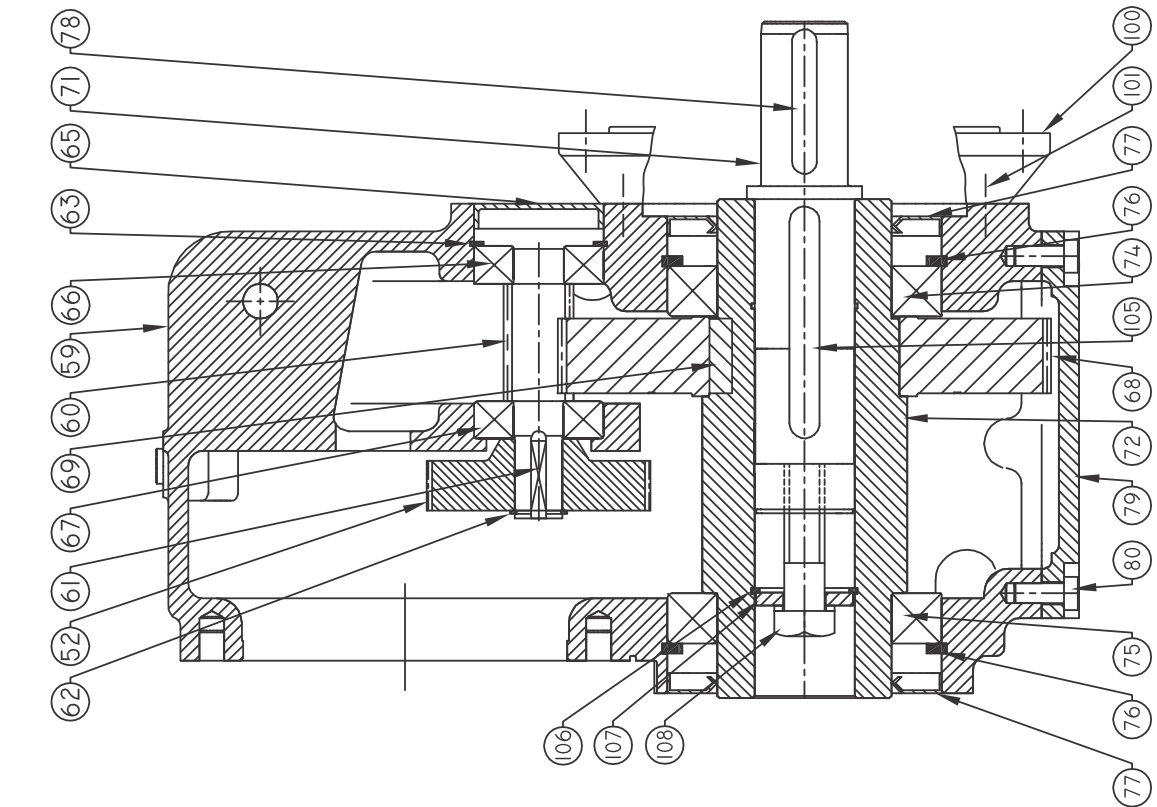

SERIES F

THREE STAGE GEARED MOTOR UNIT

F14-F25

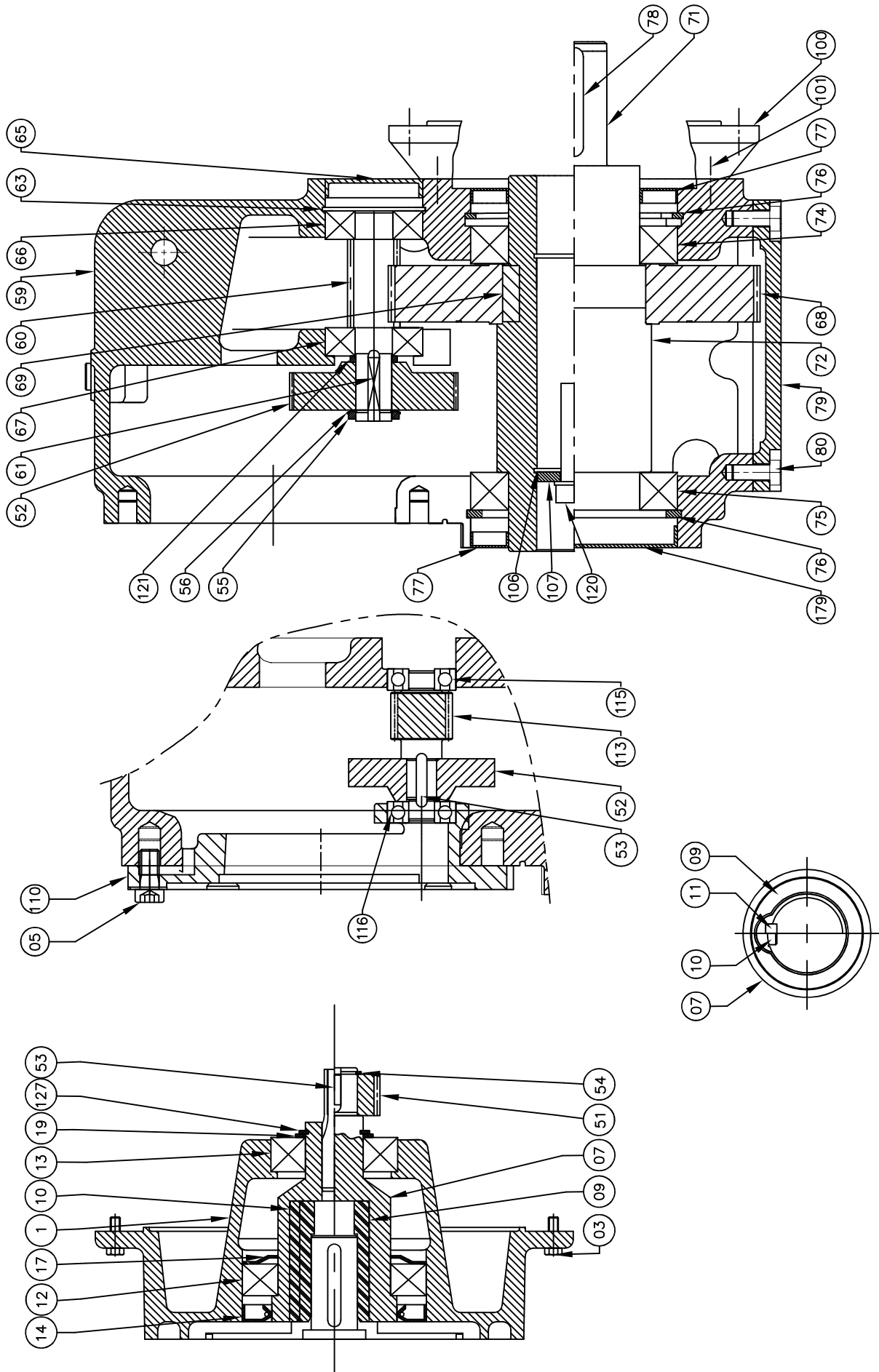

SERIES F

FOUR STAGE GEARED MOTOR UNIT

F02-F10

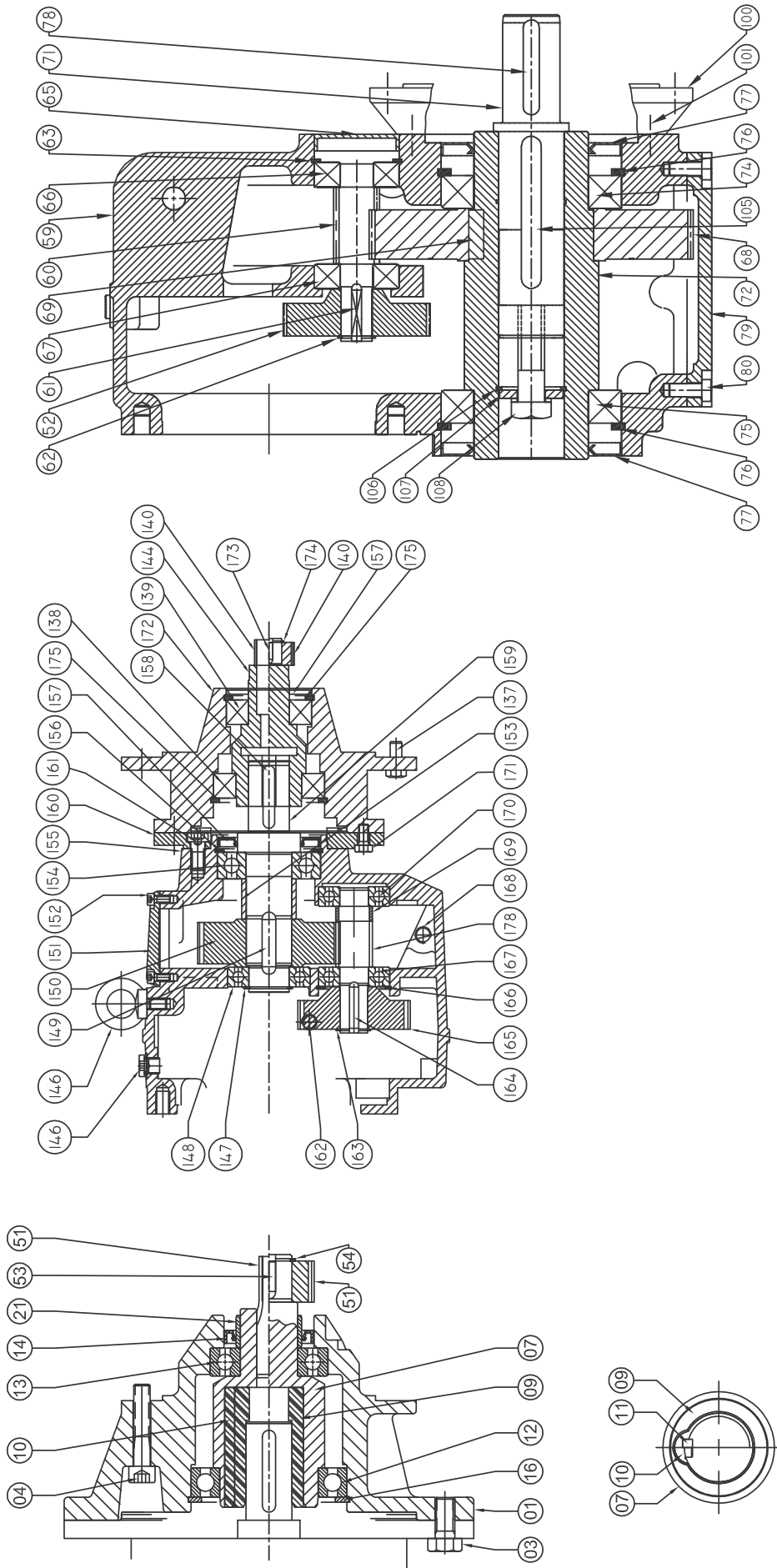

SERIES F

TWO STAGE REDUCER UNIT

F02-F10

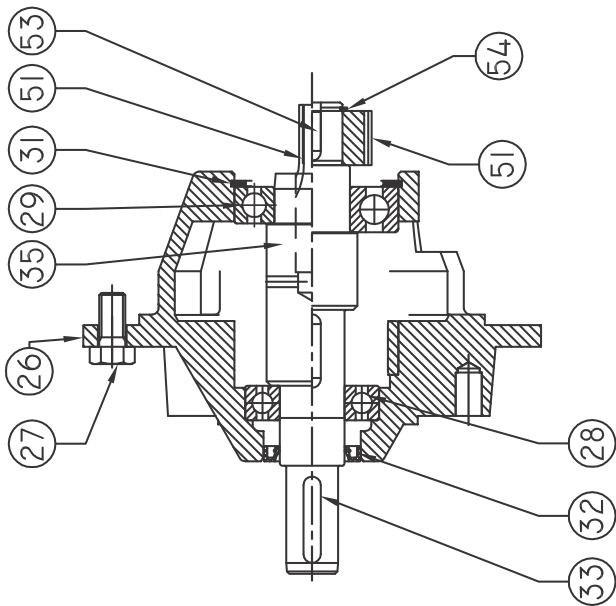
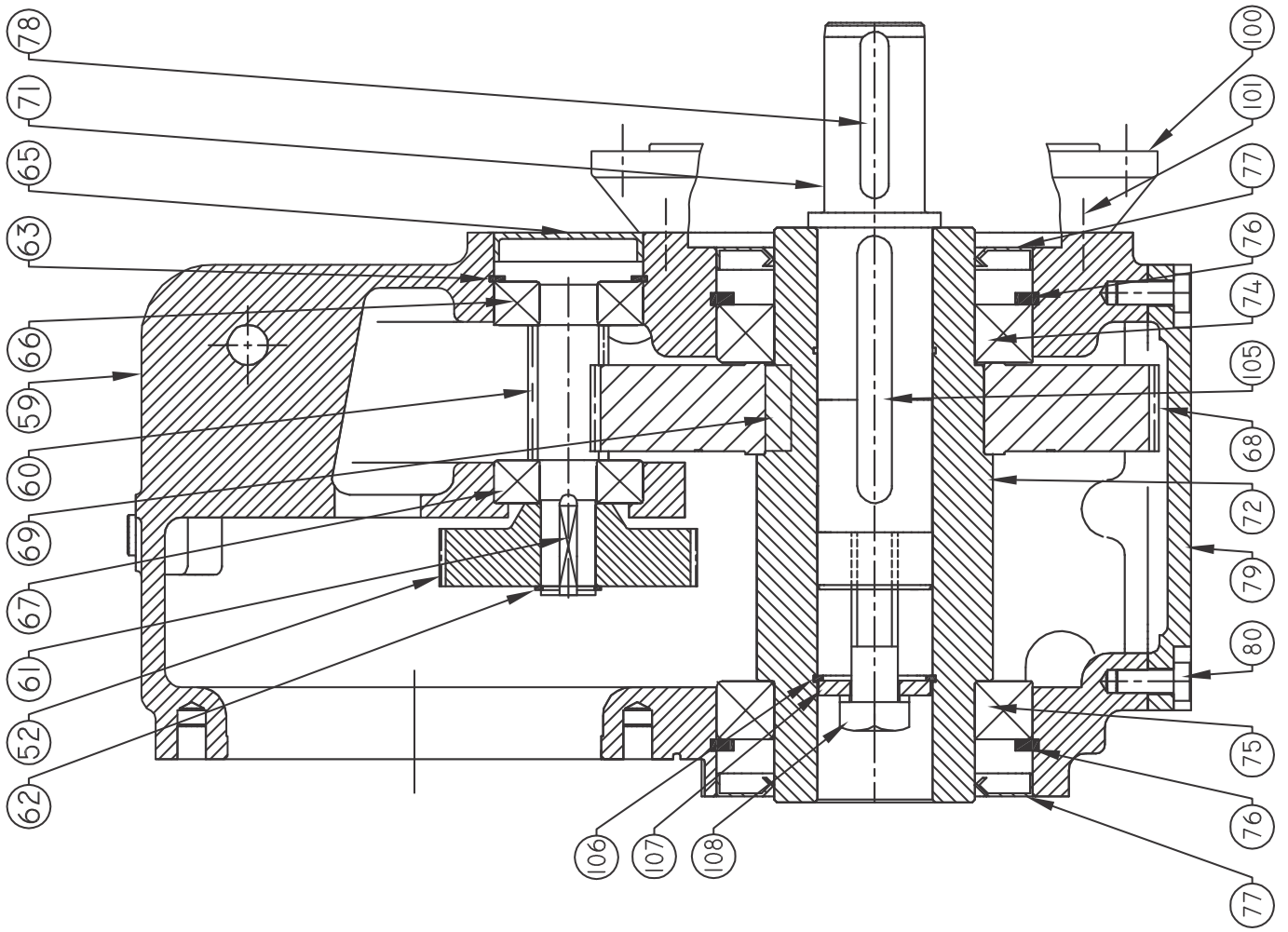

SERIES F

TWO STAGE REDUCER UNIT

F14-F25

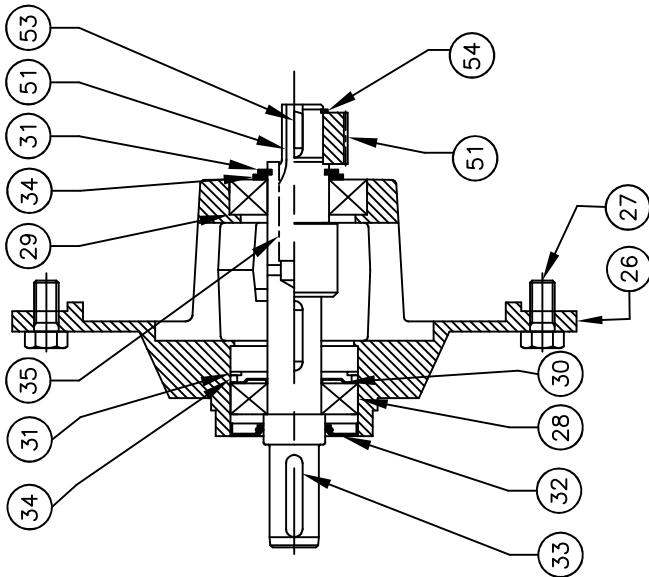
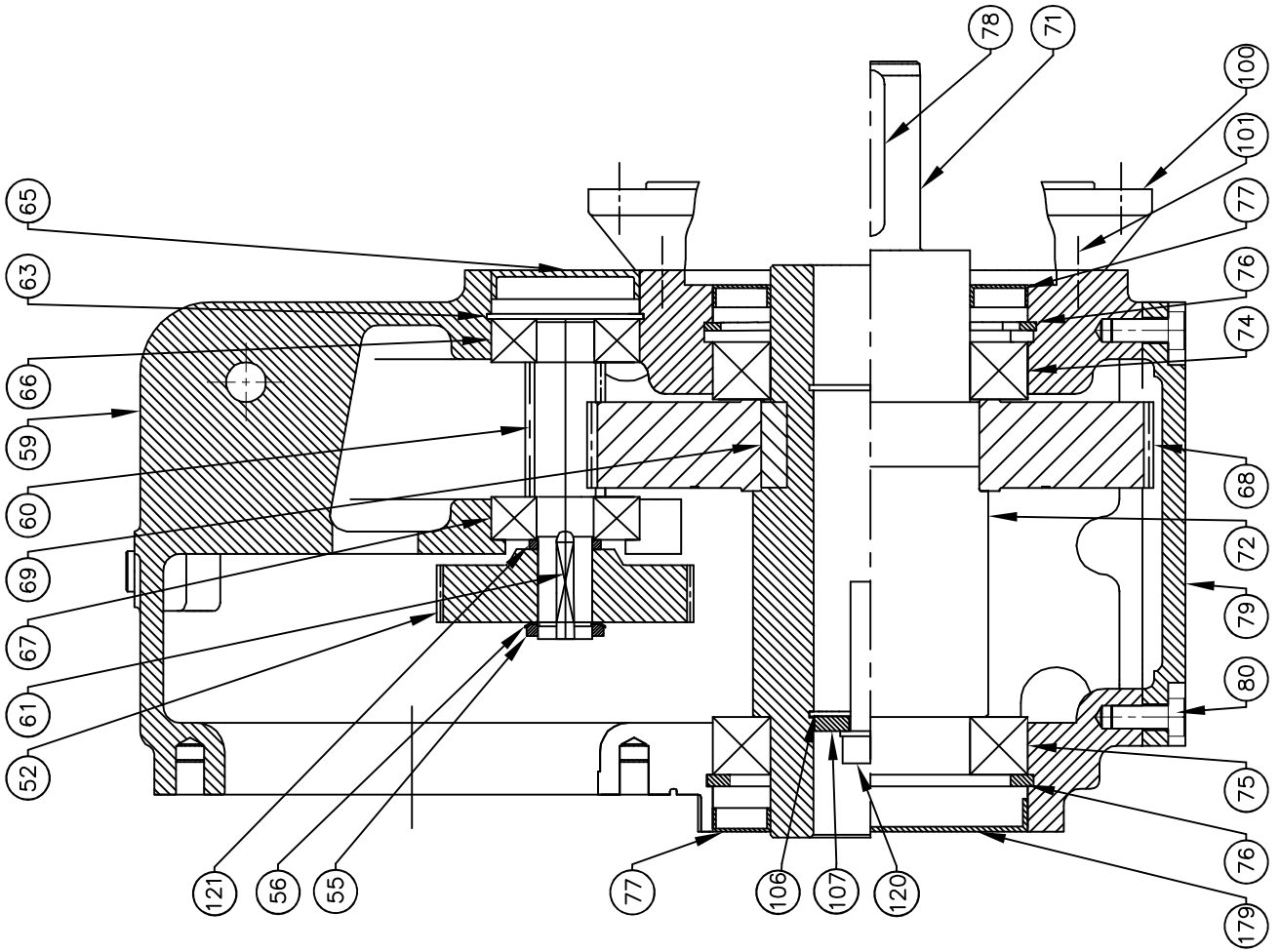

SERIES F

THREE STAGE REDUCER UNIT

F02-F10

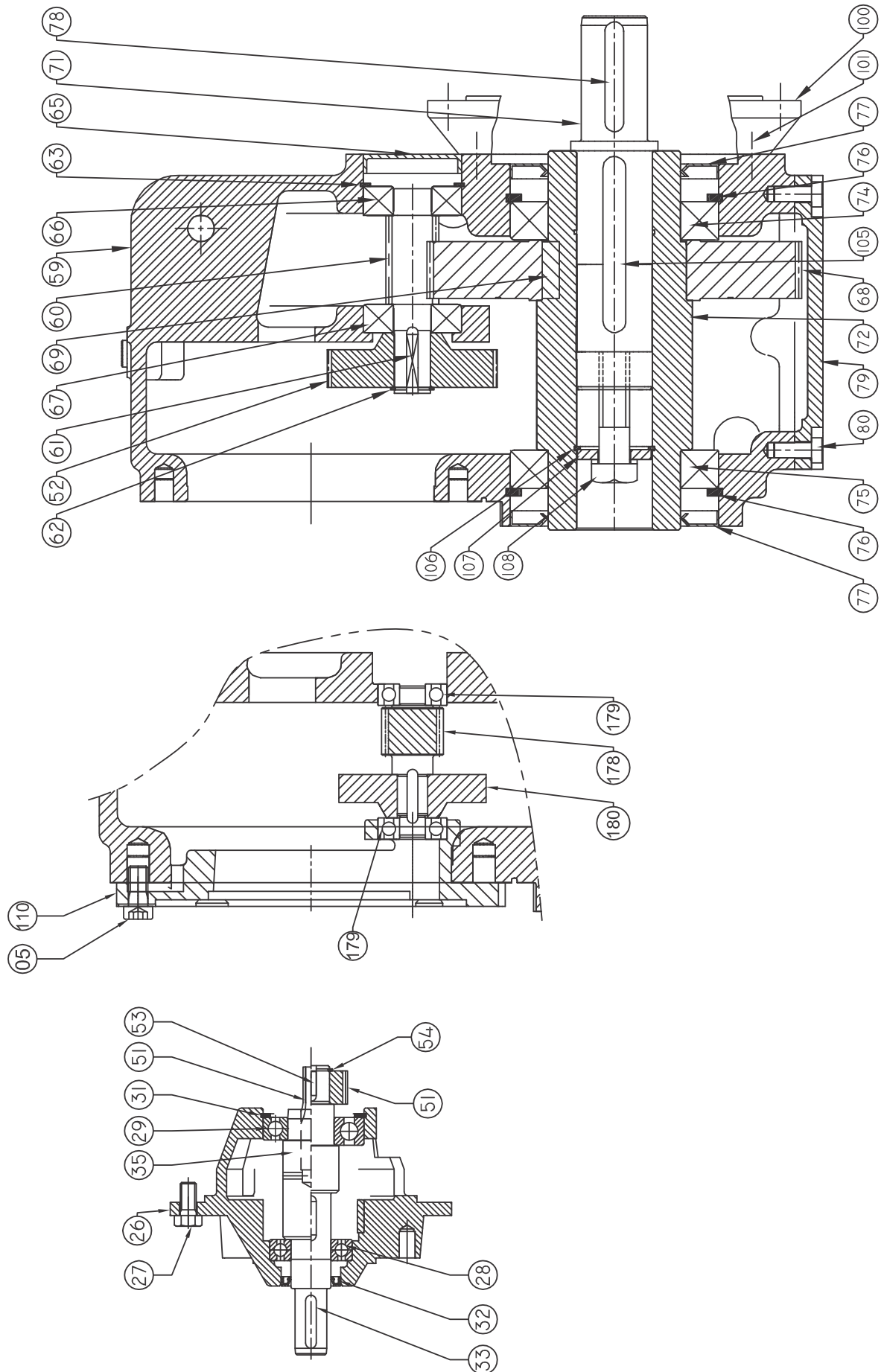

SERIES F

THREE STAGE REDUCER UNIT

F14-F25

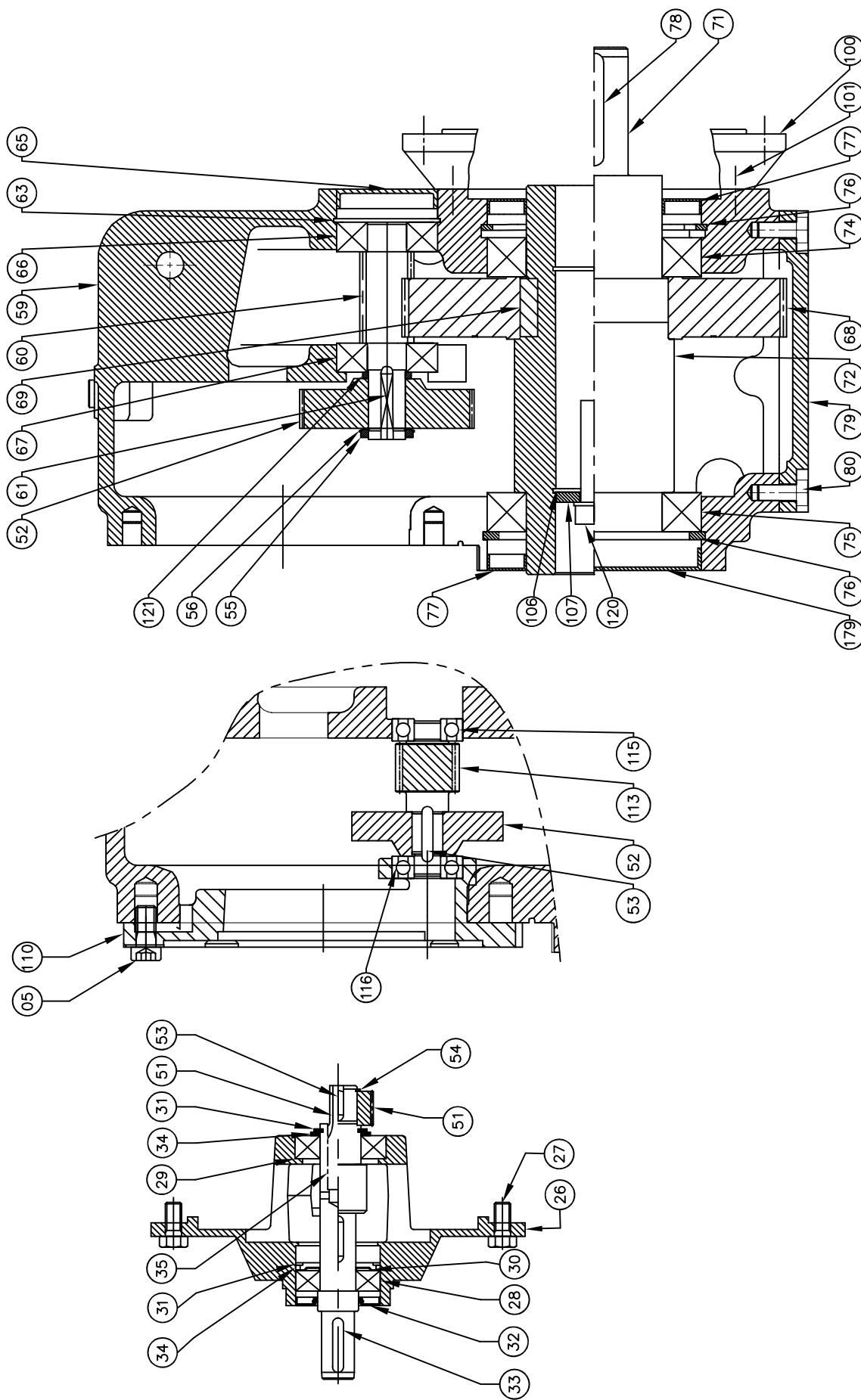

SERIES F

FOUR STAGE REDUCER UNIT

F02-F10

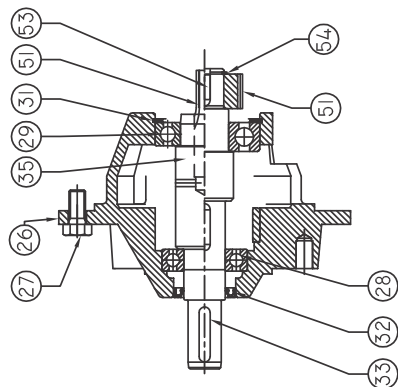
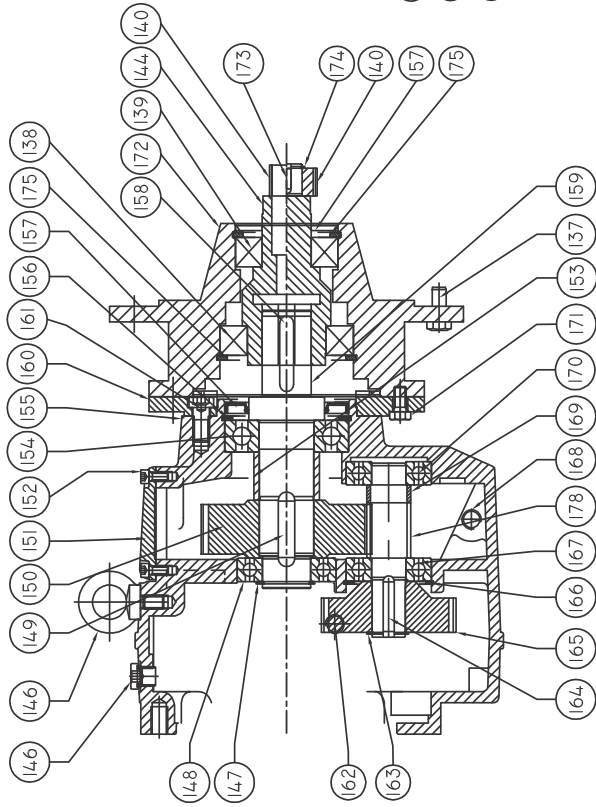
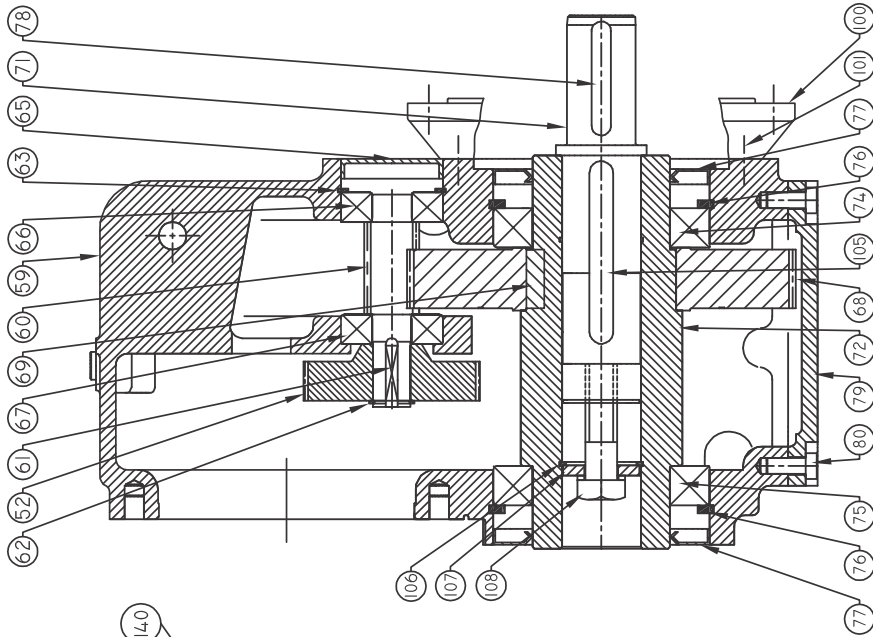

SERIES F

PART LIST

Sr.No.	Description	Sr.No.	Description	Sr.No.	Description
1	Motor Adaptor	71	O/p Shaft (M,C,F,K)(Double Extended)	126	Motor Adaptor
2	Flange (Adaptor)	72	O/p Sleeve (C,F,K)	127	External Circlip
3	Fastener (Adaptor+Motor)	73	Distance Piece (O/p Shaft/Sleeve)	128	Oil Catcher
4	Fastener (Adaptor+Flange)	74	Bering O/p Shaft (Wheel End)	129	Oil Seal
5	Fastener (Flange+Gear Case)	75	Bering O/p Shaft (O/p End)	130	Flinger
6	Nut (In Triple Only)	76	Internal Circlip O/p End Bearing	131	Lock Nut
7	Plug in Shaft	77	O/p Oil Seal	132	Lock Washer
8	Coupling	78	Key (O/p Shaft End)	133	Fasteners (Adaptor+Gear Case)
9	Motor Sleeve (Nylon)	79	Inspection Cover	134	Fasteners (Oil Catcher+Adaptor)
10	Nylon Key	80	Fastener Gear Case+Cover	135	Input Coupling
11	Key	81	Eye Bolt	136	Key
12	Bearing (Motor Side)	82	Shim	137	Screw
13	Bearing (Pinion Side)	83	Oil Level Indicator	138	Bearing (Coupling Side)
14	Oil Seal Input	84	Vent Plug	139	Bearing (Pinion Side)
15	Circlip (Pinion Side)	85	Drain Plug	140	Pinion
16	Circlip (Motor Side)	86	Bevel Pinion (K)	141	Key
17	Nilos Ring	87	Nilos Ring On FG Pinion (K03-K12)	142	Circlip (Pinion Side)
18	Grease Nipple	88	Circlip For PG Wheel on Bevel Pinion	143	Circlip (Motor Side)
19	Support Washer	89	Bearing 1 on Bevel Pinion	144	Plug in Shaft
20	Shims	90	Bearing 2 on Bevel Pinion	145	Vent Plug
21	Wear Sleeve	91	Bevel Wheel (K)	146	Eye Bolt
22-25	-	92	Key (Bevel Wheel+FG Pinion)	147	External Circlip O/p End Bearing
26	Housing Input	93	End Cover For Bevel Bore	148	Bering O/p Shaft (Wheel End)
27	Fastener Housing+Gear Case	94	Internal Circlip For FG Pinion Bearing	149	Key (FG Wheel+O/p Shaft/Sleeve)
28	Bearing (Motor Side)	95	Backstop	150	FG Wheel
29	Bearing (Pinion Side)	96	Key For Backstop	151	Inspection Cover
30	Nilos Ring-32214JV	97	External Circlip for Backstop	152	Fastener Gear Case+Cover
31	Circlip	98	Nilos Ring 1 On O/p (K09-K12)	153	Distance Piece (O/p Shaft/Sleeve)
32	Oil Seal	99	Nilos Ring 2 On O/p (K09-K12)	154	Bering O/p Shaft (O/p End)
33	Key	100	O/p Flange (M)	155	Gear Case
34	Support Washer	101	Flange Fastener (M)	156	Internal Circlip O/p End Bearing
35	Input Shaft (For Reducer)	102	FG Worm Wheel + Sleeve	157	O/p Oil Seal
36	Shim	103	FG Worm Shaft	158	Key (O/p Shaft End)
37	Grease Nipple	104	Grease Nipple (C07-C10)	159	O/p Shaft (M,C,F,K)(Double Extended)
38-49	-	105	Key (O/p Sleeve+O/p Shaft)	160	O/p Flange (Couple)
50	Input Shaft (For MMR)	106	Circlip (O/p Sleeve+O/p Shaft)	161	Fasteners (Couple)
51	Primary (PG) Pinion	107	Washer (O/p Sleeve)	162	Oil Level Indicator
52	Primary (PG) Wheel	108	Bolt (O/p Sleeve+O/p Shaft)	163	Circlip For Triple Wheel on PG Pinion
53	Key	109	-	164	Key (PG Kit Pinion+Triple Wheel)
54	Circlip	110	Triple Housing	165	Triple Wheel
55	Lock Nut	111	Triple Ring	166	Internal Circlip for Intermediate Bearing)
56	Lock Washer	112	Copper Washer	167	Bearing Input Side
57-58	-	113	Triple Pinion Shaft	168	Drain Plug
59	Gear Case	114	Triple Wheel	169	Distance Piece
60	FG Pinion Shaft	115	Bearing Input Side	170	Bearing Pinion Side
61	Key (PG Wheel+FG Pinion)	116	Bearing Pinion Side	171	Fasteners (Flange+Connecting Adaptor)
62	Circlip for PG Wheel	117	Key (PG Kit Pinion+Triple Wheel)	172	Connecting Adaptor
63	Internal Circlip for Intermediate Brg.	118	Circlip For Triple Wheel on PG Pinion	173	Circlip
64	Distance Piece FG Pinion	119	Circlip For Triple Bore	174	Key
65	End cover for FG Pinion	120	Hexagon Socket Head Cap Screw	175	Circlip
66	Bearing 1 FG Pinion	121	Distance Piece	176	Washer
67	Bearing 2 FG Pinion	122	Key (PG Kit Pinion+Primary wheel)	177	NILOS RING
68	FG Wheel	123	Washer (Bevel side)	178	FG Pinion Shaft
69	Key (FG Wheel+O/p Shaft/Sleeve)	124	Washer (FG Wheel Side)	179	End Cover
70	External Circlip O/p End Bearing	125	-		

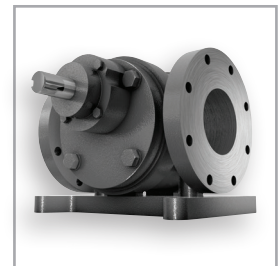
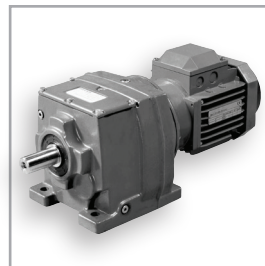
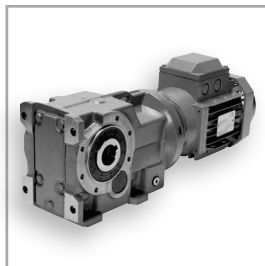
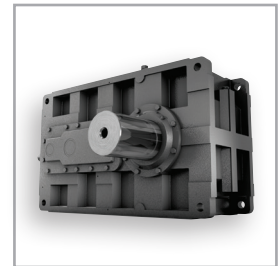
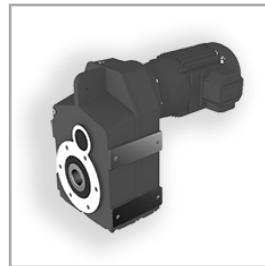
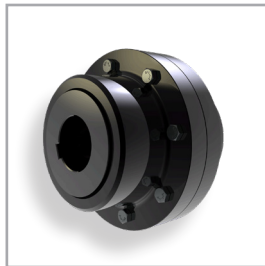
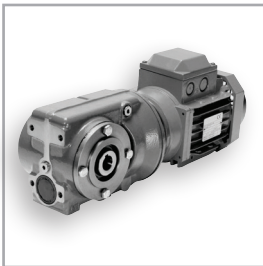
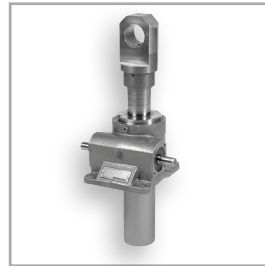

benzlers

radicon

Benzlers

Sweden	+46 42 18 68 00
Denmark	+45 36 34 03 00
Finland	+358 9 340 1716
Germany	+49 800-350 4000
Italy	+39 02 824 3511
Netherlands	+31 77 324 59 00

benzlers.se
benzlers.dk
benzlers.fi
benzlers.de
benzlers.it
benzlers.nl

Radicon

Thailand	+66 38459044
United Kingdom	+44 1484 465800
USA	+1 847 5939910

radicon.com
radicon.com
us.radicon.com