

# benzlers

with you at every turn

Series E Industrial Gear Units

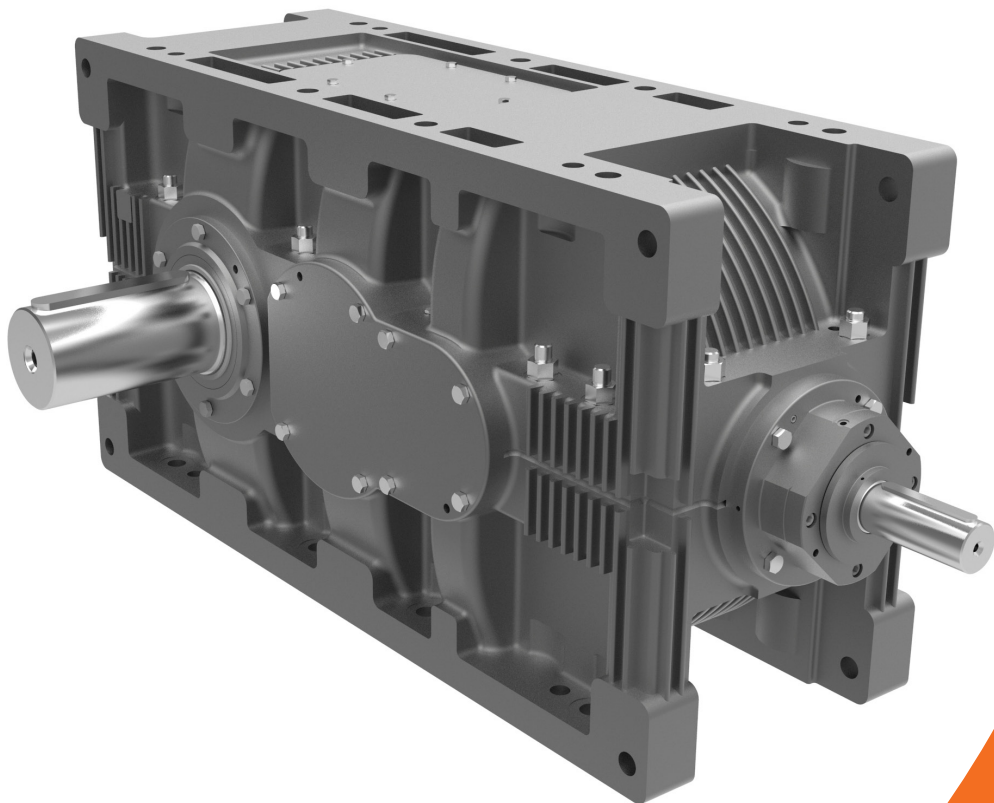

Series E

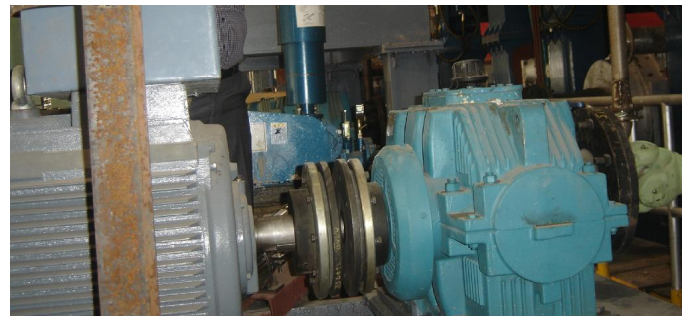
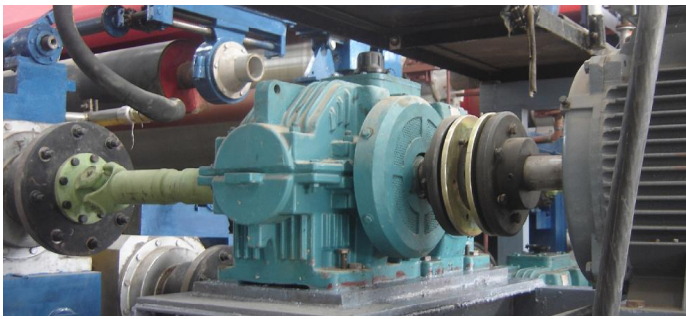

## PRODUCT INFORMATION

The Series E Industrial gear unit is designed to meet the requirements of the most demanding applications in the medium and heavy duty sectors of the power transmission market.

The modern design and construction of the Series E offers many engineering and performance benefits including a higher torque and thermal ratings, with a high degree of interchangeability of components. The gear housing has been designed to withstand the normal forces whilst reducing weight to the ideal level leading to most optimal industrial gear unit solution available.

### Unit Sizes

11,13,14,15, 16,17,18, 19, 20, 21, 22, 23, 24, 25, 26

### Types

Parallel shaft: Single, Double, Triple and Quadruple reduction  
 Right angle shaft: Double, Triple and Quadruple reduction

### Input Power

Up to 4,825Kw

### Output Torque

Up to 132,000Nm

### Gear ratios

1.25/1 to 560/1 in multistage

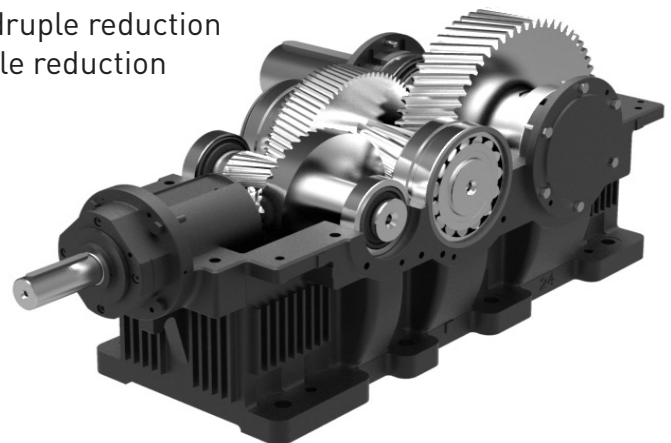

## FEATURES

Optimum case design EON

Split case design

Multimount case option EOS

Additional Cooling fins

Rigid flange output option

Labyrinth Sealing as standard

Spherical roller bearings throughout (taper roller bearings on bevel pinion shaft)

External holdback

Atex compliant

## BENEFITS

Lower weight, reducing material giving market leading torque per Kg

Ease of maintenance and in situ repair

Flexibility on mounting options

Higher thermal ratings

Ease of assembly, reduces alignment issues

Improved sealing in harsh environments

Provides longer life

Easy access for maintenance and change of direction

Can be supplied against Group 2 or 3 for surface industries in designated hazardous locations, zones 1 & 2 for gases, vapors and mist, zones 21 & 22 for dust.

## Intelligent Design

The Series E has been designed using the latest software, giving a tooth geometry which combines maximum efficiency with high load carrying capacity and minimal noise generation. Serviceability was at the forefront of our thoughts in the design guaranteeing durability, reliability and minimal downtime.

## Drop in Replacement

Our “design and supply” service enables us to supply a new drive assembly to fit directly in place of your existing equipment, we can reuse your existing motors and couplings where appropriate.

## Split design for ease of maintenance

Allows for on site inspection and maintenance eliminating costly downtime and loss of production.

## High specification seal design

Labyrinth combined with dual lip oil seals prevent the ingress of dirt and dust

## Case options

Available with dedicated foot mounted case EON, which gives the optimum torque/kg, or with multimount case EOS giving flexibility on mounting options.

**EOS**

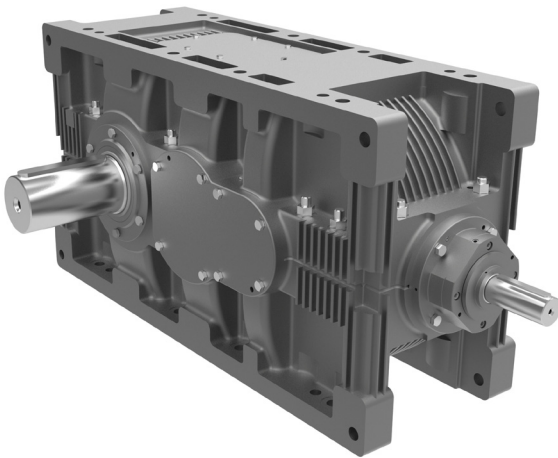

**EON**

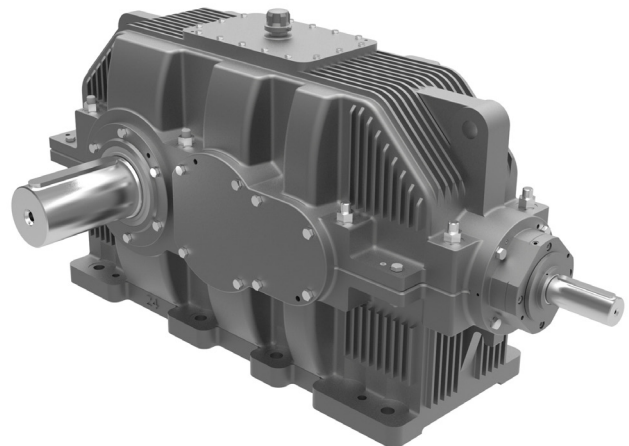

## Typical Applications and Industries

### Applications

Conveyors  
Crushers  
Cranes  
Seed Presses  
Steam Condensers  
Mixers  
Test Rig  
Winches  
Pumps  
Mixers  
Cooling Towers

### Industries

Cement  
Mining  
Harbours and Ports  
Quarrying  
Power Generation  
Petrochemical  
Steel  
Pulp & Paper  
Food & Beverage  
Water and waste water

**Benzlers** believes in engineering quality relationships with our customers that strengthen what we can achieve together. Our business and the people within our business are committed to building long lasting partnerships that are as reliable as our products and as smooth as our service.

Benzlers and sister company Radicon are now part of Elecon Engineering, Asia's largest and fastest growing gear manufacturer. This partnership means that we can offer our customers an enhanced range of standard and bespoke engineering solutions including drop in replacements, all supplied with the product quality and engineering expertise demanded from and delivered by the Benzlers business.

**Benzlers - with you at every turn**

benzlers 

radicon 

**Benzlers**

Denmark +45 36 340300

Finland +358 9 3401716

Germany +49 800 3504000

Italy +39 02 8243511

Sweden +46 42186800

The Netherlands +31 77 3245900

[www.benzlers.com](http://www.benzlers.com)

**Radicon**

Thailand +66 3845 9044

United Kingdom +44 1484 465800

USA +1 847 5939910

[www.radicon.com](http://www.radicon.com)